



Design and Implementation of Power Converters with a Unified Structure and Adaptive Sliding Mode Controller for Green Energy Harvesting

Lokesh D ^{1,*}, Dr.C.Senthilsingh ²

Abstract

Technological advancements promote the harness of renewable energy and this has led to address the increase in energy requirements, exploitation of fossil fuels and to limit the emission of greenhouse gases. Sustainability of the environment is seriously disturbed caused by the threat of unacknowledged policies of non-renewable energy sources' exploitation. Having the benefits of being non-polluting, noise-free and universal availability, solar and wind energy become a perennial source of renewable energy. With the advent of new electrical standards, hybrid systems are devised as a unified structure for efficient power management and balance of energy needs. Proposed system introduces a model for DC-DC buck converter, and output is converted into AC with three phase voltage inverter along with estimations of space vectors and total harmonic distortion. The proposed DC-DC converter model intense to produce a new power conversions circuit with minimal complexity in design and execution. Similarly, electronic devices function without any controlling mechanism and in an open loop mode. There are multiple systems which mandate are a controlling mechanism to regulate voltage or current at a prescribed level, to accommodate load variations. Adaptive sliding mode controller is presented with the design of the hybrid system for governing speed of response, compensation off load variations and overcome steady state error. From the simulation results, it is observed that the proposed design performs better than conventional standards of power conversion. The performance of sliding mode controller was tested against the performance of traditional standards of SMC and PWM. From such investigations, it is evident that a hybrid system with controlling mechanism ensures better performance

6411

Key Words: DC-DC Buck Converter, Boost Converters, DC-AC converter, inverters, Power Factor Controller, modified sliding function.

DOI Number: 10.14704/nq.2022.20.8.NQ44665

NeuroQuantology 2022;20(8):6411-6418

Introduction

Renewable energy sources are readily available and perennial, cost effective and pollution free. With ever increasing pollution in Metropolitan cities, governments have regulated their policies in adoption of renewable energy sources ranging from electric cars

to solar power for homes. The power requirement of every nation is increasing with population explosion, upcoming industries, vehicles and almost every other function [1-3]. Photovoltaic energy and wind energy are available for utilisation throughout the year, which has been concentrated in multiple researches.

Corresponding author: Lokesh D

Address: ^{1,*}, ²Department of Computer Science and Engineering, Infant Jesus College of Engineering, Thoothukudi, Tamilnadu, 628851, India

^{1*}E-mail: lokeshphd1989@gmail.com

Relevant conflicts of interest/financial disclosures: The authors declare that the research was conducted in the absence of any commercial or financial relationships that could be construed as a potential conflict of interest.

Received: 13 March 2022 **Accepted:** 18 April 2022



With technological advancements, it is imperative to design and deploy a hybrid energy generation system combining multiply the sources of renewable energy. Hybrid systems will also include battery sources for storing generated energy whenever available. In a bad climatic condition, solar and wind energy will be limited, rising the need of backup stored in energy banks. Availability of power, even in times of bad weather conditions, is the benefit of a hybrid energy system [5]. There are conditions where excess energy has been generated beyond the requirement, energy banks in terms of an equipped battery within the system to properly store the surplus and distribute it for later use.

It is understood that there are multiple technical difficulties associated with storing energy in banks which was generated by renewable energy resources. Huge demand for regulation and controlling mechanism rises within a hybrid system to monitor the flow of power throughout. Various algorithms have been proposed for balancing the energy requirements and the utilisation for optimising the cost of production and distribution [4]. Power interfaces were designed to declare strategies of management in case of multiple power sources and unlimited connections to Electronic devices. In a grid-tier architecture, high voltage boosting will be found predominantly, owing to light coupled inductor, intermediate capacitor and leakage. DC-DC converters with leakage energy recovery was implemented to address these issues. Efficiency of the converters depends on the count of switching frequencies, in turn resulting in switching losses. High performance controller have to be designed in order to mitigate the switching losses occurring due to high frequency. The design of an optimal converter will be subjected to different contrasts of power and transient loads. Likewise, proper design of a small scale grid can result in efficient testing and functioning.

The proposed work justifies the design of a hybrid system with sufficient energy storage banks and efficient design of a converter using micro grids. This system is a incorporated version of photovoltaic and wind energy along with power banks. Integration of 3 different components together adds challenge to the design and implementation. Other factors which influence the proposed model are instability, load demand, switching and complex communication between the different components. Energy Management algorithms car designed with fuzzy, neuro fuzzy and Optimisation techniques. Fuzzy Logic

controller insured better outcomes during the management of solar [6] and wind energy generation equipment with power bank. Particle Swarm Optimisation ensured better outcomes with respect to local best and global best during shifting uncertainty.

In such applications, power source and load demand hugely vary due to multiple uncertainties, adding a burden in the functionality of DC-DC converters. Voltage outcome from such converters can be drastically affected during voltage and power perturbations. Conventional linear control strategies cannot be applied onto a hybrid architecture due to its inability to control fluctuating power and voltage demands. Sliding mode controller word introduced in in variable structures and were defined with a nonlinear controlling approach. Stability was considerably improved despite the presence of modelling imperfections, external disturbances and insensitivity. Numerous researches in the recent decade, have proposed controlling mechanism using sliding mode controller [7-10]. Simpler and easier designs of Buck, Boost and Boost-Buck converters have been introduced with analogue implementation of sliding mode controller. Insensitivity of boost converters can be eradicated with an improved SMC. SMC implemented over a Cuk converter outperformed the functionality of PI controller. The problems found in a traditional sliding mode controller are the relative degree with respect to sliding variable and derivatives retrieved from the variable u .

The sliding mode controller based buck converters have the need for estimating the capacitor current and converter output voltage. Both these estimations happen in parallel. DC-DC power converters states that the output current is directly proportional to time derivative of output voltages. When the output voltage is set to follow the sliding variable of the proposed scheme, a differentiator can be deployed to measure the difference in voltage. This decision can eliminate the need of capacitor sensors, usually installed to measure the current, which in turn reduces the component cost from the whole design. The accuracy of the said differentiator plays a significant role in deciding the performance of entire system. Noise, by default, will be added to the input of a differentiator which can be eliminated in an ideal environment. The design of the differentiator should be optimized to limit the input noise and thus ensure robustness. In the proposed model, the second order



sliding mode controlling scheme will derive the right order of sliding variable. The proposed system intends to optimize the design of a DC-DC power converter, and a sliding mode controlling algorithm to ensure standard functions even during the load disturbances. The article is organized into the following sections, Section II reviews and lists the existing models of converter and controlling mechanism derivations. Section III illustrates the architecture of the proposed scheme and Section IV illustrates the performance of various state of art techniques comparatively. Section V concludes the article with supporting references.

Related Work

Various researches have documented the design and implementation of converters with controllers for generating energy from renewable energy sources. Every technique intends to utilise renewable energy sources and extract the maximum potential energy in its own aspect. A hybrid energy generation system [11-15] what's the time with the combination of photovoltaic cells, natural gas and a fuel cell for distributing and electrical supply to homes. Meta heuristic algorithms namely Particle Swarm Optimisation was backed up with adaptive inertia weight and constriction factor in some algorithms. Outcome of two factors processed by the algorithm was subjected to huge variations. This issue was addressed by extending the functionalities of other meta heuristic algorithms such as genetic algorithm and competition algorithm along with particle Swarm Optimisation. An economical and suitable model for homes was designed with a combination of solar, wind and fuel cell to constitute the structure of power and heat system. Predominantly, genetic algorithm and particle Swarm Optimisation were the top rank options in the design of hybrid power systems [16-20]. Optimisation was attained by these metaheuristic algorithms to reduce the operational and overhead cost.

Self-adaptive differential evolution algorithm was proposed to equip the hybrid power systems with power banks. Using a multi objective technique, the model was able to address issues associated with cost of electricity, renewable factor and loss of power supply probability. The hybrid system was updated into to a distribution centre with AC/DC micro grids. An interlinking converter facilitated the operations of distribution, and control the source of power generation with particle Swarm Optimisation techniques. PSO improves dynamic functionality of the hybrid system by mastering the control of power sources and distribution. Many authors advocated that

a model has to be designed and implemented with an Optimisation technique with meta heuristic algorithms for simplified and improvised access. The model was designed with optimal power flow through HVDC and offshore WPP. Flat tie-line power controller was built with solar energy generator circuit, wind energy turbine in a hybrid design using MG. This methodology attempted to limit the power ramp and smoothening the operations of power handling. Managing power in AC DC micro clips was investigated with a multi objective particle Swarm Optimisation technique. State of charge is an important measure of battery condition in the deployment of hybrid micro grids. Design of hybrid systems were also reliant on the price of the hardware and quality of the entire system.

Three phase with multistage converters, photovoltaic generator with Perturb and Observe along with Power Point Tracking controlling mechanism was proposed. A hysteresis controlling mechanism facilitated the control of three phase inverters. Genetic Algorithm with Particle Swarm Optimisation ensured the determination of soil strength and deployed in an excavation project in Tehran. A method to the controlling mechanism for compensating simple and direct working sags was achieved with an ATP-EMTP software application. DC to DC power converters are the preferred option to regulate output voltage despite being in the generic, lower or higher energy forms. Being built with lesser number of components [21], DC to DC converters are implemented in different architectures. The converter in order to achieve regulated load and input voltage mandate the process of controllers for enhanced tolerance level and reduced aging. Boost converters predominantly used in photovoltaics energy generation systems [22-24]. Yet these converters fail to perform in open loop conditions as they do not meet the requirements for stabilizing voltage and dynamic ability. DC to DC converters are usually nonlinear and do not adhere for linear control strategies due to their time-variant functionalities. Sliding mode controller will be a suitable option for producing the converters to operate in wide functioning condition [25]. Sliding mode control mechanism following the hysteresis mechanism will address noise and frequent switching operations [26-27]. Such drawbacks have to be addressed in the deployment of hysteresis based controller [28]. The proposed solution should also meet the cost required for constructing the entire



Proposed System

The proposed scheme implements an interleaved Buck Converter, which is a predominant option in industrial applications. Applications which necessitated optimal converter dynamics and reduced filters can suitably opt

interleaved Buck Converters for their operations. Despite the functional benefits in real time scenarios, Buck converters are said to possess small duty ratio in presence of high voltage requirements. The mentioned problems can be eradicated when a series of capacitors are built in buck converter to ensure upgraded performance. Configurations and Waveforms of the proposed methodology resembles the performance and structure of series capacitor converters [26]. The intention of the proposed method is to enhance the switching functionality in high side switches, and reducing the drain to source voltage. The efficiency of proposed method reduced the high switch voltage stress. Architecture of the proposed method is illustrated in Figure 1 and 2.

The common understanding of the proposed model is that the ideal resistance is presented in all resistors. In figure 2, the proposed capacitor is placed in parallel to the voltage input. This is to ensure that the capacitors will be charged prior to the switch voltage level. During the commencement, switch voltage will be kept under the limit and hence capacitor gets powered up. Switching signals present in the circuit will be handled by the Switches and diodes will be responsible for discharging the energy stored [29-31]. The proposed scheme can be enriched with more number of capacitors, without increasing the number of capacitors in a traditional design of the Buck converters. Figure 1 illustrates the architecture of Hybrid Renewable Energy Sources with photovoltaic cells, wind turbines and an energy bank along with additional load input. Bus facilitates the connectivity between different components and energy generated from PV cells and wind turbines. The bus is also responsible for transferring harvested energy to the DC-AC micro grid for actual utilization. Both the PV cells and wind turbines are connected to the proposed Buck Converters and energy bank is connected to a DC-DC bidirectional converters. The proposed architecture is also connected to a controlling scheme which facilitates inductance and load resistance. In standard operating conditions, S1 and S4 switches are ON and Switches S2 and S3 are

turned OFF. L1 will be charging as S1 is turned ON and current flows through the circuit as permitted by S4.

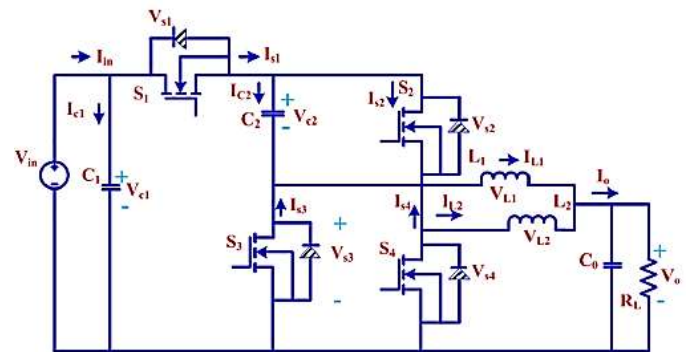

Figure 1: Circuit Diagram of the proposed methodology
Figure 2: Architecture of the Proposed System

3.2 FUNCTIONS OF TRADITIONAL SMC

The processes of a sliding mode controller are a collection of two important sub-processes. Switching manifold has to be defined in the first process to reflect on the dynamic abilities of the entire circuit. The next equation states the discontinuous state law u to be followed by the sliding mode controlling mechanism in ideal conditions.

$$u = \begin{cases} u^+ & S(x) > 0 \\ u^- & S(x) < 0 \end{cases} \quad (1)$$

The limits of S ranges from -0 to +0. In an ideal linear estimation, the relative degree will be in two forms with respect to state space.

$$\dot{x} = a(t, x) + b(t, x) u \quad (2)$$

It is observed that $x \in R$, i.e. the sliding variable. The state variable x_1 and x_2 are observed in a matrix where a, b is considered to be the smoothing variables. The sliding surface is determined by the following equation, which also derives the controlling law for the proposed DC-DC buck converter.

$$SL = k\sigma + \sigma (\sigma = v_0 - V_{ref}) \quad (3)$$

$$u = \frac{1}{2} (1 - (sign)S) \quad (4)$$

Sliding model controlling scheme can be derived from sliding mode initiator phase and reaching phase. It should be noted that the values of x_1 and x_2 in traditional SMC design will exponentially lead to 0. Proportional Derivative is the variant of feedback system, found in conventional SMC. Steady State Error shall be attenuated with a single and double integral element with all steady state variables over a sliding surface. The existing scheme of operations will



considerably surge the controlling factors, impacting the design and functionality of the overall design. This drawback can be addressed with the design of controlling scheme in the proposed methodology.

3.3 Proposed Controller Strategy

The design of the proposed Buck Converter can be optimized with respect to control by implementing non-linear control schemes.

Proposed controllingscheme

can be mathematically expressed using the following formats. S indicates the switches, D denoting the diodes, L indicates the inductance, C denoting the series of capacitors and R denoting the resistance values of the proposed design of Buck Converters. The variable switching is performed by the proposed SMC algorithm. The said model can be written in the following mathematical format.

$$\begin{bmatrix} \dot{x}_1 \\ \dot{x}_2 \end{bmatrix} = \begin{bmatrix} 0 & 1 \\ -\frac{1}{LC} & -\frac{1}{RC} \end{bmatrix} \begin{bmatrix} x_1 \\ x_2 \end{bmatrix} + \begin{bmatrix} 0 \\ \frac{v_{in}}{LC} \end{bmatrix} u + \begin{bmatrix} 0 \\ -\frac{v_{ref}}{LC} \end{bmatrix} \quad (5)$$

The DC-DC converter will function based on the two relative degrees. The second order sliding mode controller scheme ensures better accuracy and reduced convergence time. Prescribed Convergence Law is used to define the second order sliding mode controller accordingly, based on the following equation.

$$u = \alpha \operatorname{sign}(\sigma + \beta |\sigma|^{1/2} \operatorname{sign} \sigma) \quad (6)$$

Both the values of α & β are greater than 0. From the proposed design of the controller, it is obtained that the value of $\sigma \equiv 0$, representing the dynamic ability of sliding functions. The control signal is a binary representation of power, denoting 1 for ON and 0 for OFF. With the values of Km and H as the following mathematical representations, the convergence law can be expressed in an updated form as follows.

$$K_m = \min\left(\frac{1}{LC} V_i\right) \quad (7)$$

$$H = \frac{1}{C} \left(\frac{1}{L} V_0 + \frac{1}{R} i\right) \quad (8)$$

$$u = \frac{1}{2} (1 - \operatorname{sign}(\sigma + \beta |\sigma|^{1/2} \operatorname{sign} \sigma)) \quad (9)$$

In the proposed second order sliding mode controller, design parameter β should be able to satisfy the condition $K_m - H > \frac{\beta}{2}$. This condition is to acknowledge that convergence is greater and finite according to the proposed second order based convergence. The rate of convergence is directly proportional to the Beta value, i.e. greater the value of β denotes greater convergence of the proposed DC-DC Buck converter.

RESULTS AND DISCUSSIONS

The proposed hybrid energy generation from renewable sources with second order sliding model controller is implemented with SIMULINK application. The said second order sliding mode controlling scheme has promised optimal control signal received from both photovoltaic cells and wind turbines. The performance of the entire system is estimated with respect to the output generated from PV, wind and energy banks. System design is tested for irradiation of PV and wind's speed. The performance of hybrid

system is compared against the performance of Particle Swarm Optimization and the second order sliding mode controller is tested against the performance of conventional sliding mode control scheme. When the wind speed hugely varies under irradiation, simulation results portray the performance in terms of voltage, current and power signal after the application of proposed control measure. The time interval for plotting the graph was considered to be 0 to 1, with a standard depiction at 35A. The signal strength of PV was constant at the mentioned parameters. In the next figure, the wind current signal will be considered between the timeline 0.9-1. Both the considerations depicted the energy bank to peak at 350A, and increases to reach 380A at 1 s and are illustrated in Figure 4.1 respectively. The next figure 4.2 illustrates the constant irradiance of PV power, wind energy and thus energy banks.

6415

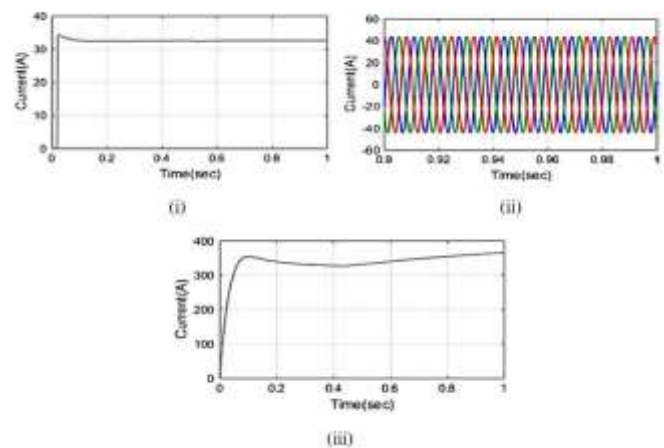

Figure 3. (i) PV current, (ii) wind energy (iii) energy bank current



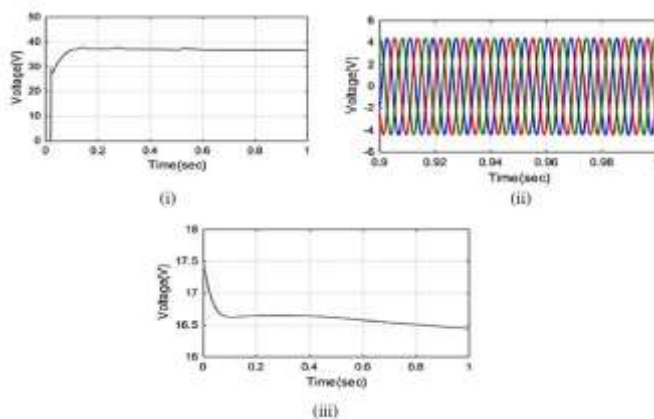

Figure 4. (i) PV voltage (ii) Wind Energy voltage (iii) Energy bank voltage

The effectiveness and reliability of the proposed control scheme is compared against the conventional sliding mode controller scheme. Design parameters and circuit factors are listed in the table below.

Table 1. Parameters for Simulation

Parameter	Value
Input Voltage	15V
Reference Voltage	5V
Resistance	10 Ohm
Capacitance	4700
Inductance	2mH
K	85
β	70

The simulated environment has set the voltage of the controller as 15V, the load resistance to 2.5 – 10 Ohm maximum. Simulated Buck converters have produced the following current and voltage curves under the standard and proposed SMC in Figure 4.3. From the obtained results, when k and β values are set higher, output voltage is obtained faster. The proposed mechanism has identified that when the controller parameters are set to exceed the nominal level, the voltage convergence and overshoot current and voltages. In order to balance the overshoot, nominal value will be obtained by the consideration of $k = \frac{1}{RXC}$. R denotes the resistance of the series Buck converter and C indicates the capacitance values. From the results of simulations, the two controlling schemes have shown significant reliability under load disturbances.

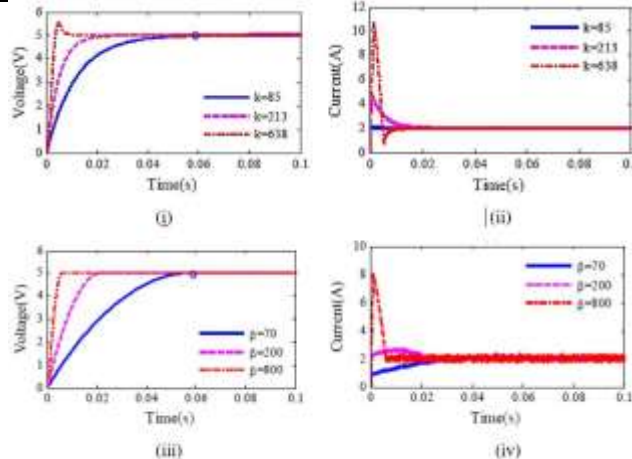

Figure 5. significant reliability under load disturbances

The following results signifies that transient voltage is dropped in the same level in both the conventional and proposed controlling schemes. Drop of voltage was measured to be up to 25mV. This drop will be determined based on the performance of buck converter circuits and load current. Observed recovery time was estimated to be 30ms for conventional SMC circuit and the proposed second order sliding mode controller exhibited 2ms. From the results, it is evident that proposed scheme delivered better reliability.

CONCLUSION

The article summarizes the performance of a highly reliable converter with a second order sliding mode controlling mechanism to be implemented in a hybrid renewable energy generation system. The proposed system is compared against the conventional controlling schemes, simulated in a SIMULINK platform. The performance is evaluated in terms of irradiances for the series Buck converter and controller is evaluated against standard methods. Simulation results evaluated individual power and current of PV cells, wind energy and energy banks. The obtained results prove that the proposed system outperforms better in terms of current, voltage. Controlling mechanism was defined as a non-linear mechanism with better accuracy and reliability to voltage and current disturbances. With the addition of series capacitors, current sensor can be removed from the hardware design for converter controls. As a future direction, a current sensor can be implemented for increasing sensitivity and availability of DC-DC buck converters. Continuous operations of converters can be detected by monitoring the utilization of different components. Proposed methodology with enhanced controlling strategy can efficiently implemented in hybrid energy generation systems from renewable sources. The model also required lesser number of

6416



components and improved reliability.

REFERENCES

- Kurs A, Karalis A, Moffatt R, Joannopoulos JD, Fisher P, Soljacic M. Wireless power transfer via strongly coupled magnetic resonances. *science*. 2007 Jul 6;317(5834):83-6.
- Adly M, Strunz K. Irradiance-adaptive PV module integrated converter for high efficiency and power quality in standalone and DC microgrid applications. *IEEE Transactions on Industrial Electronics*. 2017 Aug 4;65(1):436-46.<https://doi.org/10.1109/TIE.2017.2723860>.
- Lu X, Niyato D, Wang P, Kim DI, Han Z. Wireless charger networking for mobile devices: Fundamentals, standards, and applications. *IEEE Wireless Communications*. 2015 Apr 29;22(2):126-35.
- Olvitz L, Vinko D, Švedek T. Wireless power transfer for mobile phone charging device. In *2012 Proceedings of the 35th International Convention MIPRO 2012 May 21 (pp. 141-145)*. IEEE.
- Azharuddin Shamshuddin M, Babu TS, Dragicevic T, Miyatake M, Rajasekar N. Priority-based energy management technique for integration of solar PV, battery, and fuel cell systems in an autonomous DC microgrid. *Electric Power Components and Systems*. 2017 Oct 21;45(17):1881-91.<https://doi.org/10.1080/15325008.2017.1378949>.
- Changizian M, Zakerian A, Saleki A. Three-phase multistage system (DC-AC-DC-AC) for connecting solar cells to the grid. *Emerging Science Journal*. 2017 Nov 14;1(3):135-44.<https://doi.org/10.28991/ijse-01116>.
- Zhang F, Liu X, Hackworth SA, Scabassi RJ, Sun M. In vitro and in vivo studies on wireless powering of medical sensors and implantable devices. In *2009 IEEE/NIH Life Science Systems and Applications Workshop 2009 Apr 9 (pp. 84-87)*. IEEE.
- Wang J, Li J, Ho SL, Fu WN, Li Y, Yu H, Sun M. Lateral and angular misalignments analysis of a new PCB circular spiral resonant wireless charger. *IEEE Transactions on Magnetics*. 2012 Oct 18;48(11):4522-5.
- Venkataramanan R. Sliding mode control of power converters. California Institute of Technology; 1986.
- Utkin V. Sliding mode control of DC/DC converters. *Journal of the Franklin Institute*. 2013 Oct 1;350(8):2146-65.
- Dhua D, Huang S, Wu Q. Optimal power flow modelling and analysis of hybrid AC-DC grids with offshore wind power plant. *Energy Procedia*. 2017 Dec 1;141:572-9.<https://doi.org/10.1016/j.egypro.2017.11.076>.
- Do HL. Non-Isolated High Step-up DC-DC Converter with a Coupled Inductor. In *Advanced Materials Research 2012 (Vol. 424, pp. 1024-1027)*. Trans Tech Publications Ltd.<https://doi.org/10.4028/www.scientific.net/AMR.424-425.1024>.
- Saad NH, El-Sattar AA, Mansour AE. A novel control strategy for grid connected hybrid renewable energy systems using improved particle swarm optimization. *Ain Shams Engineering Journal*. 2018 Dec 1;9(4):2195-214.<https://doi.org/10.1016/j.asej.2017.03.009>.
- Konjedic T, Korošec L, Truntič M, Restrepo C, Rodič M, Milanovič M. DCM-based zero-voltage switching control of a bidirectional DC-DC converter with variable switching frequency. *IEEE Transactions on Power Electronics*. 2015 Jun 24;31(4):3273-88.<https://doi.org/10.1109/TPEL.2015.2449322>.
- Koutroulis E, Kalaitzakis K, Voulgaris NC. Development of a microcontroller-based, photovoltaic maximum power point tracking control system. *IEEE Transactions on power electronics*. 2001 Jan;16(1):46-54.
- Kumar RS, Girirajkumar SM. Particle Swarm Optimization Recurrent Neural Network Based Z-source Inverter Fed Induction Motor Drive. *Research Journal of Applied Sciences, Engineering and Technology*. 2014 Jun 20;7(23):4973-85.<https://doi.org/10.3233/IFS-151552>.
- Tiwari SK, Singh B, Goel PK. Design and control of microgrid fed by renewable energy generating sources. *IEEE Transactions on Industry Applications*. 2018 Jan 15;54(3):2041-50.<https://doi.org/10.1109/TIA.2018.2793213>.
- Saljoughi AS, Mehrvarz M, Mirvaziri H. Attacks and intrusion detection in cloud computing using neural networks and particle swarm optimization algorithms. *Emerging Science Journal*. 2017 Dec 30;1(4):179-91.<https://doi.org/10.28991/ijse-01120>.
- Singh SS, Fernandez E. Modeling, size optimization and sensitivity analysis of a remote hybrid renewable energy system. *Energy*. 2018 Jan 15;143:719-31.<https://doi.org/10.1016/j.energy.2017.11.053>
- Mamarelis E, Petrone G, Spagnuolo G. Design of a sliding-mode-controlled SEPIC for PV MPPT applications. *IEEE Transactions on Industrial Electronics*. 2013 Oct 25;61(7):3387-98.

6417



- Lopez-Santos O, Martinez-Salamero L, Garcia G, Valderrama-Blavi H, Sierra-Polanco T. Robust sliding-mode control design for a voltage regulated quadratic boost converter. *IEEE transactions on power electronics*. 2014 May 21;30(4):2313-27.
- Oucheriah S, Guo L. PWM-based adaptive sliding-mode control for boost DC–DC converters. *IEEE Transactions on industrial electronics*. 2012 Jun 7;60(8):3291-4.
- Sahraoui H, Drid S, Chrifi-Alaoui L, Hamzaoui M. Voltage control of DC-DC buck converter using second order sliding mode control. In 2015 3rd International Conference on Control, Engineering & Information Technology (CEIT) 2015 May 25 (pp. 1-5). IEEE.
- Yigeng H, Yu W. A robust flyback converter based on high order sliding mode control for fuel cell. In IECON 2014-40th Annual Conference of the IEEE Industrial Electronics Society 2014 Oct 29 (pp. 3936-3940). IEEE.
- Xiao ZX, Guerrero JM, Shuang J, Sera D, Schaltz E, Vásquez JC. Flat tie-line power scheduling control of grid-connected hybrid microgrids. *Applied Energy*. 2018 Jan 15;210:786-99. <https://doi.org/10.1016/j.apenergy.2017.07.066>.
- Yeh CA, Lai YS. Digital pulsewidth modulation technique for a synchronous buck DC/DC converter to reduce switching frequency. *IEEE Transactions on industrial electronics*. 2011 Apr 19;59(1):550-61. <https://doi.org/10.1109/TIE.2011.2143381>.
- Zheng Y, Jenkins BM, Kornbluth K, Træholt C. Optimization under uncertainty of a biomass-integrated renewable energy microgrid with energy storage. *Renewable energy*. 2018 Aug 1;123:204-17. <https://doi.org/10.1016/j.renene.2018.01.120>.
- Komurcugil H. Non-singular terminal sliding-mode control of DC–DC buck converters. *Control Engineering Practice*. 2013 Mar 1;21(3):321-32.
- Liu J, Laghrouche S, Harmouche M, Wack M. Adaptive-gain second-order sliding mode observer design for switching power converters. *Control Engineering Practice*. 2014 Sep 1;30:124-31.
- Levant A. Robust exact differentiation via sliding mode technique. *automatica*. 1998 Mar 1;34(3):379-84.
- Davila J, Fridman L, Levant A. Second-order sliding-mode observer for mechanical systems. *IEEE transactions on automatic control*. 2005 Nov 14;50(11):1785-9.

