



SMART BATTERY PACK MANAGEMENT SYSTEM FOR NEXT-GENERATION ELECTRIC SCOOTERS

¹Balu Badhavathu,²Dr.Ranjith Kumar Katkuri,³Mr.Raju Chintakindi,⁴Komakula Vishal,
⁵Dasari Ganesh

¹³Assistant Professor,²Associate Professor,⁴⁵Students
Department of EEE

Vaagdevi College of Engineering, Warangal, Telangana

ABSTRACT

This project focuses on the design and development of a Battery Pack Management System (BMS) for electric scooters, aimed at optimizing performance, safety, and energy efficiency. As electric scooters continue to gain popularity in urban transportation, the demand for reliable and efficient battery management systems has increased. The proposed BMS is designed to monitor battery health, manage charging and discharging cycles, balance cell voltages, and provide real-time diagnostics to prevent overcharging, overheating, and deep discharging. By implementing advanced algorithms for energy management and state-of-charge estimation, this BMS enhances the lifespan and safety of the battery pack while improving the scooter's overall performance. Experimental testing demonstrates the system's ability to maintain optimal battery conditions under various operational loads, positioning it as a robust solution for sustainable and efficient electric scooter usage. This research contributes to the advancement of electric mobility by providing a practical framework for enhancing battery performance and safety in lightweight electric vehicles.

DOI Number: 10.48047/nq.2022.20.8.nq221173

NeuroQuantology 2022;20(8):11353-11362

INTRODUCTION

The rise of electric mobility, particularly in urban areas, has led to a surge in demand for efficient, reliable, and sustainable electric scooters. A key component determining the effectiveness and safety of these scooters is the battery pack, which must meet rigorous performance and durability standards under varying conditions. However, without a well-designed Battery Management System (BMS), battery packs are susceptible to issues like overcharging, overheating, imbalanced cells, and excessive discharge—problems that can drastically reduce battery lifespan and compromise safety.

A BMS plays a critical role in monitoring and controlling various

parameters of the battery pack, ensuring it operates within safe and optimal limits. By providing real-time data on cell voltages, state-of-charge (SOC), temperature, and current, a BMS not only protects the battery from potential hazards but also optimizes performance, extending battery life and enhancing overall scooter efficiency. Additionally, an advanced BMS contributes to energy efficiency by balancing the power output and input, allowing for longer travel distances and reducing energy wastage.

This project focuses on the design and development of an advanced BMS tailored specifically for electric scooters. Leveraging modern sensor technology and control algorithms, this system aims to provide comprehensive monitoring, accurate SOC



estimation, and efficient power management. The following sections outline the methodology, development process, and performance evaluation of the BMS, illustrating its potential to enhance electric scooter performance, sustainability, and user safety in urban transportation environments. Through this work, we aim to contribute a robust solution for optimizing battery management, supporting the growth of electric mobility solutions worldwide.

The duty cycle of PWM is set by the pulse width since the frequency stays the same while the on off time changes. In PWM the power goes up as the duty cycle goes up. A DC (direct current) motor turns DC (direct current) electricity into mechanical energy. It makes the motor shaft rotate mechanically and the shaft is physically connected to a machine or other mechanical device to do work. DC motors work well in a lot of different industrial settings. DC motors for example are used when the speed or position of the load needs to be controlled precisely and when the motor needs to speed up or slow down quickly and smoothly. Plus, the direction could be changed easily.

Literature survey

The advancement of Battery Management Systems (BMS) for electric vehicles, particularly lightweight vehicles like electric scooters, has been widely explored in recent years. Research in this area emphasizes the need for effective battery management to enhance safety, efficiency, and battery longevity.

1. Battery Management System Architecture and Functions:

A study by Zhang et al. (2018) provides an overview of BMS architectures, focusing on centralized, modular, and distributed configurations and their impact on system complexity, scalability, and cost. The authors highlight that centralized BMS designs, though cost-effective, can be limited by scalability issues, whereas modular and distributed

designs provide improved reliability and flexibility but at a higher cost. Functions such as cell balancing, state-of-charge (SOC) estimation, and fault detection are identified as essential to ensuring stable battery performance and extending battery lifespan.

2. State-of-Charge and State-of-Health Estimation:

Accurate SOC and State-of-Health (SOH) estimation are critical functions of a BMS. Plett (2015) and other researchers have explored various techniques, including Coulomb counting, open-circuit voltage (OCV) estimation, and machine learning-based methods. While Coulomb counting is widely used for its simplicity, it can suffer from inaccuracies due to drift over time. Advanced approaches, such as Kalman filtering and artificial neural networks, have shown to be effective in enhancing SOC and SOH estimation accuracy, thus ensuring a more reliable assessment of battery life.

3. Cell Balancing Techniques:

Cell imbalance can lead to decreased battery efficiency and a shorter lifespan. Research by Shen et al. (2019) delves into passive and active cell balancing techniques, outlining their respective benefits and drawbacks. Passive balancing, although simple and cost-effective, dissipates excess energy as heat, potentially affecting battery temperature. Active balancing, on the other hand, redistributes energy among cells, minimizing energy loss and enhancing overall efficiency. The study emphasizes the importance of choosing a balancing method that aligns with the system's power and thermal management needs.

4. Thermal Management in Battery Packs:

Thermal management is a crucial aspect of battery pack design. Lin et al. (2020) investigated various cooling techniques, including air and liquid cooling, phase change materials, and heat pipes. Efficient thermal management is essential in preventing overheating, especially during high-power discharge cycles, as overheating can lead to reduced battery life and safety risks. Studies

have shown that incorporating thermal management within the BMS can improve battery performance and ensure safe operation under different environmental conditions.

5. Safety and Fault Diagnosis Mechanisms:

Safety in battery operation is paramount, particularly with the increased risks associated with lithium-ion batteries. Hannan et al. (2021) reviewed the implementation of fault diagnosis systems within BMS, including real-time monitoring of voltage, current, and temperature to detect and mitigate safety risks such as overcharge, short circuit, and thermal runaway. Fault detection and prediction algorithms have been developed to alert users or automatically shut down the system, ensuring a safe and controlled environment for battery operation.

6. Emerging Technologies and Future Directions:

Recent advancements, such as integrating machine learning and IoT in BMS, are paving the way for smarter and more adaptable battery systems. Research by J. Wang et al. (2022) explored the use of predictive maintenance and machine learning algorithms to enable real-time data analysis, enhance fault detection, and improve SOC and SOH estimations. The development of such "smart" BMS could revolutionize battery management by enabling adaptive responses to dynamic usage patterns and environmental conditions.

In conclusion, the literature highlights the essential functions and technologies necessary for effective BMS design, including SOC estimation, cell balancing, thermal management, and fault diagnosis. By building on these foundations and integrating modern algorithms and sensor technologies, this study aims to design a robust BMS specifically tailored to meet the demands of electric scooters, ultimately contributing to safer, more efficient, and longer-lasting battery systems.

PROPOSED SYSTEM CONFIGURATION

The escalated increase of oil prices due to resource depletion, global warming issues and enforcement of compulsory standard gas emissions in the cities attribute tremendous impact in developing new transportation technology these days. Thus, an alternative solution like the HEV with its consumption efficiency, economical value and lower toxic gas emission is anticipated to be the technology of the future. The term HEV refers to cars in most cases, whereas the term small HEV is restricted to referring to scooters or three-wheeled vehicles. The automotive industry recognizes that electric vehicles (EVs) and hybrid electric vehicles (HEVs) are in the forefront for fuel efficiency, and reduced emissions. One major challenge for the high voltage battery in the HEVs is to have a long operating life, and yet have a high charge-discharge cycle rate in order to:

i. Recover as much of the vehicle's kinetic energy as possible

ii. To supply high peak energies on demand

Hence, the problem addressed in this project is to improve driving range by improving energy storage system. And to observe the battery function with different charging sources.

In this project, two simulation models are used. The first model has batteries of nickel metal hydride and the second model is a hybrid model made of fuel cells, super capacitor and batteries. The PI controller with PWM is designed to control the speed and rotation of the machine. And a system is designed to maintain the voltage and SOC in batteries and to protect and recharge them. The picture 1 is the simulation model for battery working without BMS. In this, the battery is getting discharged and is not protected. And the waveforms for this is shown respectively [5.1.a and 5.1.b] where the voltage and SOC are decreasing with time. The envisioned circuit diagram of a multi-tenant rescue helicopter switch (mlcc) for such a dc power framework is seen in fig.4.1. The above tried to suggest system that consists of envisioned electrolytic capacitors wall h bridge form in order to manage this same orientation of a vehicle dynamic

permanent magnet synchronous engine along with countless regulate slabs a certain organize as well as maintaining the order a function of that very software. Therefore, in research it and recommended multistory heli loop (mlcc) is still a 5 and 8 power conversion and although demonstrated in fig.4.2 this consists of four voltage regulation switches Controller design for any system needs knowledge about system behavior. Most of the time this means giving a mathematical description of how the process inputs state variables and outputs are related. The mathematical equations that describe how the system works (the process) are called a

model of the system. This paper talks about a good way to learn about power electronic converters analyze them and simulate them by using system level nonlinear and switched state space models. Power converters can be simulated in a useful way with the help of the MATLABSIMULINK software package. The goal of this study is to make models for all basic converters and study how they work when there is no load on them. These models can then be used to design any close loop scheme. Also, as a full exercise a closed scheme case with cascaded control for a boost converter has been looked at.

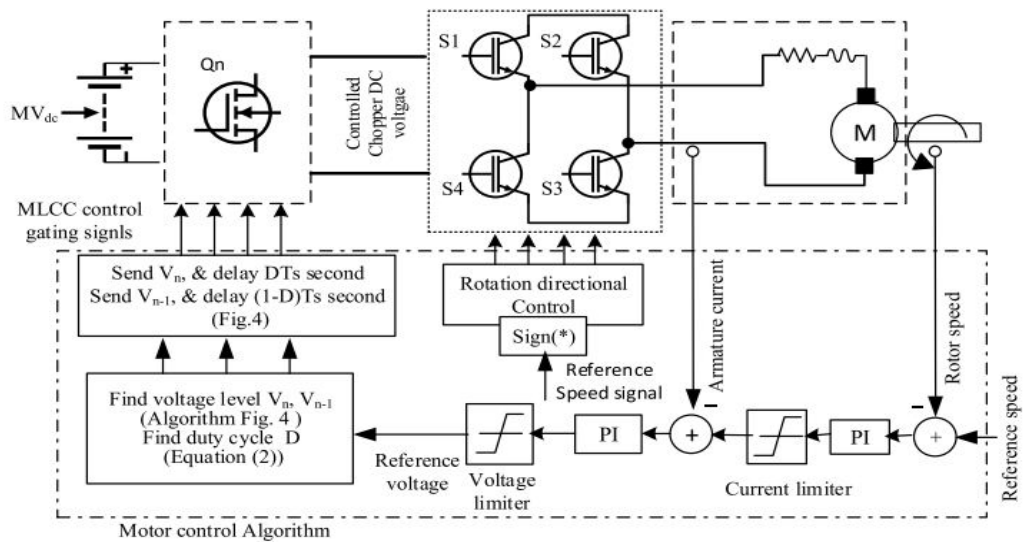

Fig 1 Block Diagram of MLCC driving a DC motor

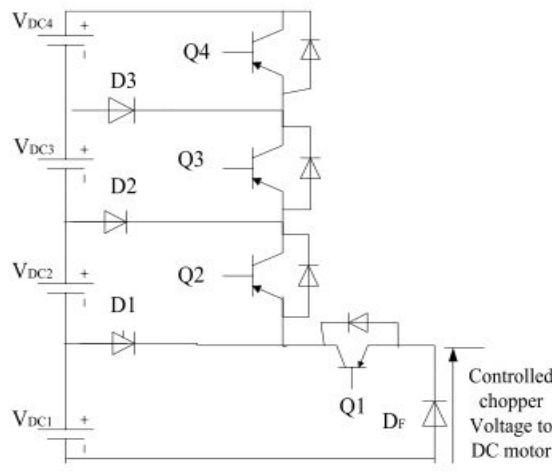

Fig 2 Configuration of 5-level diode clamped multilevel chopper circuit(MLCC)

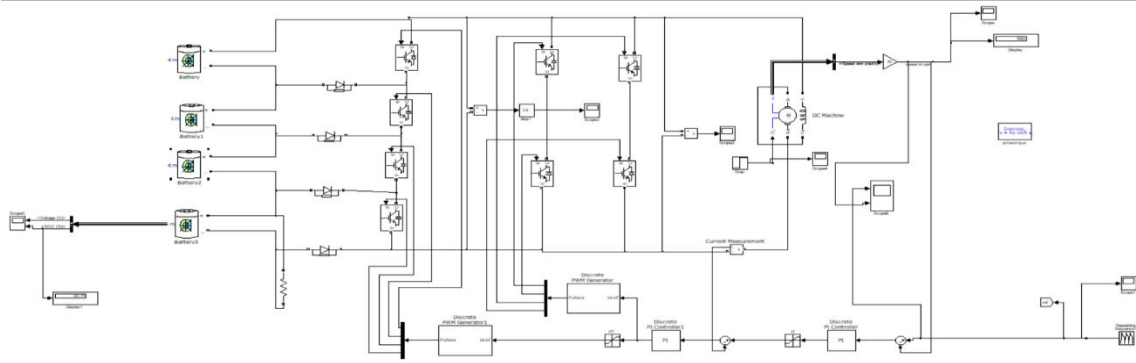

Fig 3 Battery Pack Without BMS

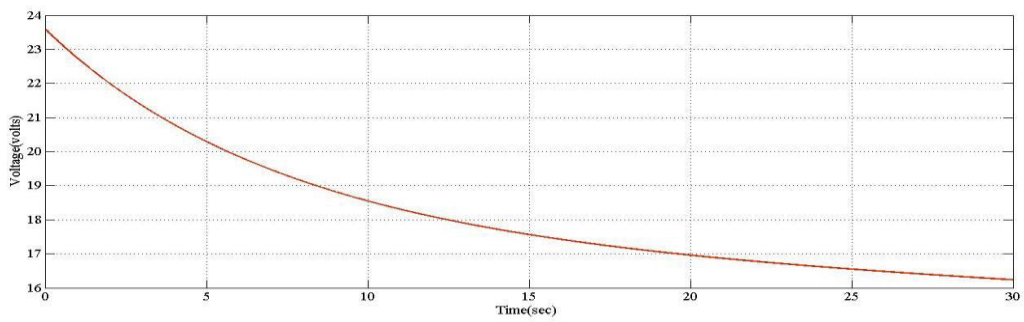

Fig 4 Voltage of Battery without BMS

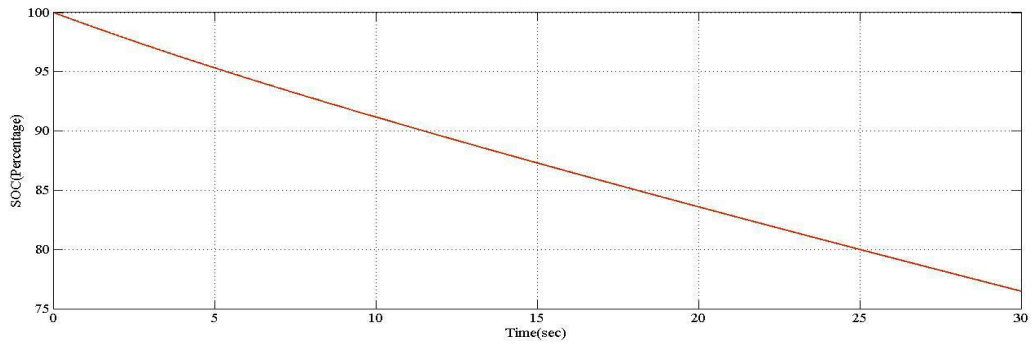

Fig 5 SOC of Battery without BMS

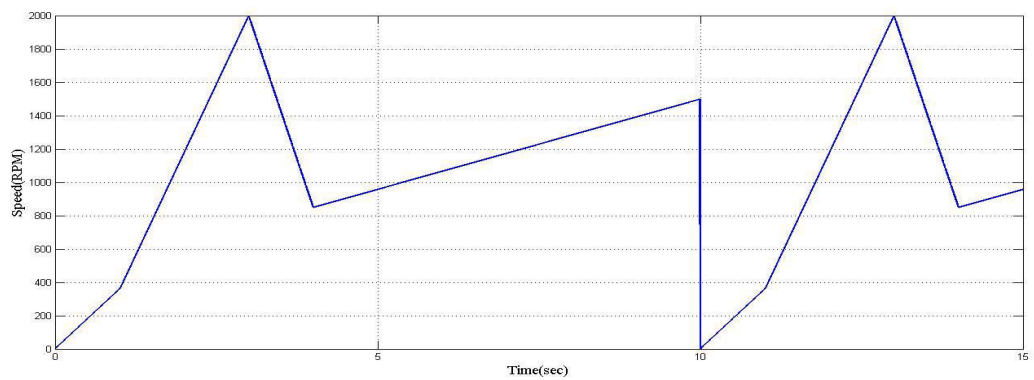

Fig 6 Desired Speed input

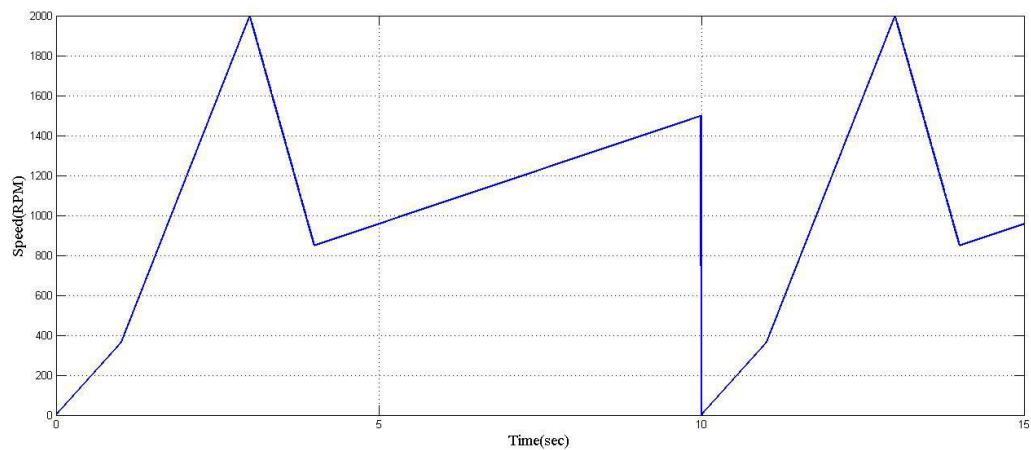

Fig 7 Speed output of the Vehicle

The figure shows the battery pack with BMS and it's working. Here, the battery pack is recharged with the BMS circuit and the SOC is always maintained between 95% to 100%. It is simulated for 30 seconds and the waveforms are shown below [5.2.a, 5.2.b, 5.2.c and 5.2.d].

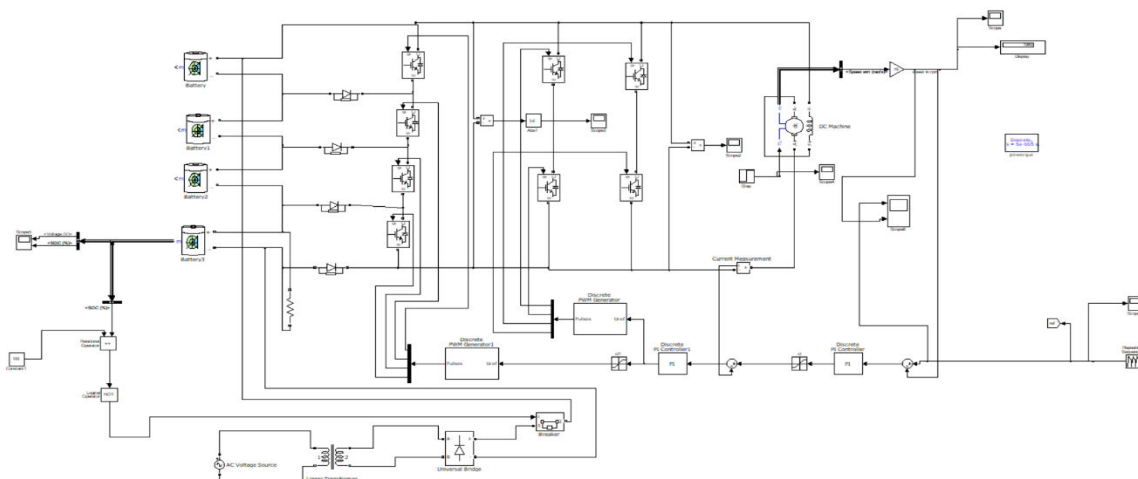

Fig 8 Proposed circuit configuration for Battery Pack with BMS

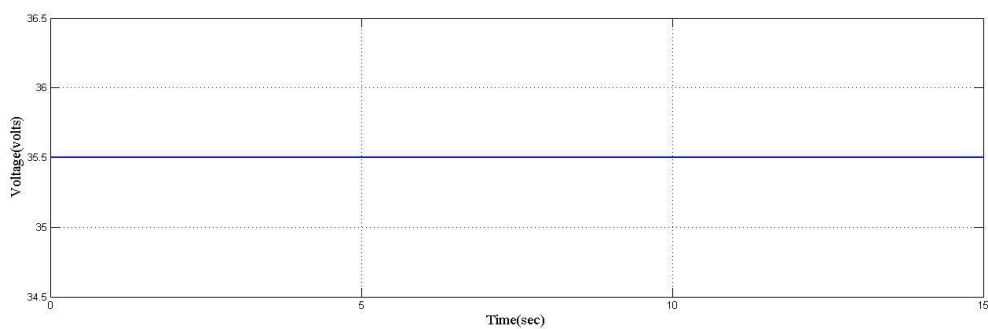

Fig 9 Voltage of Battery with BMS

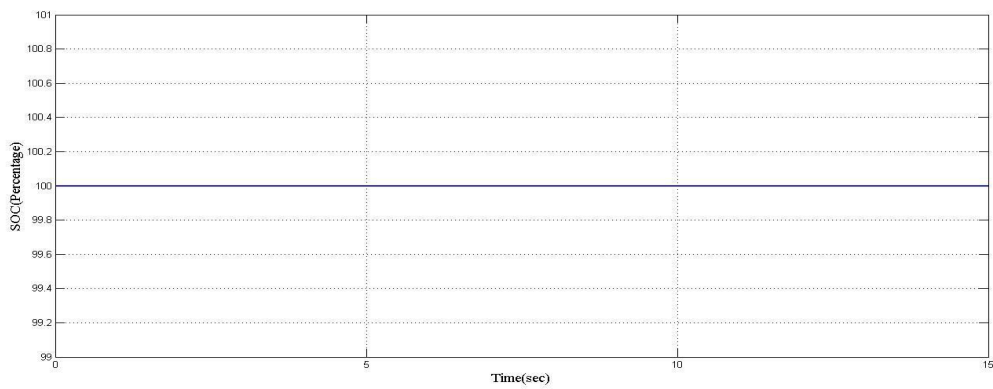

Fig 10 SOC of Battery with BMS

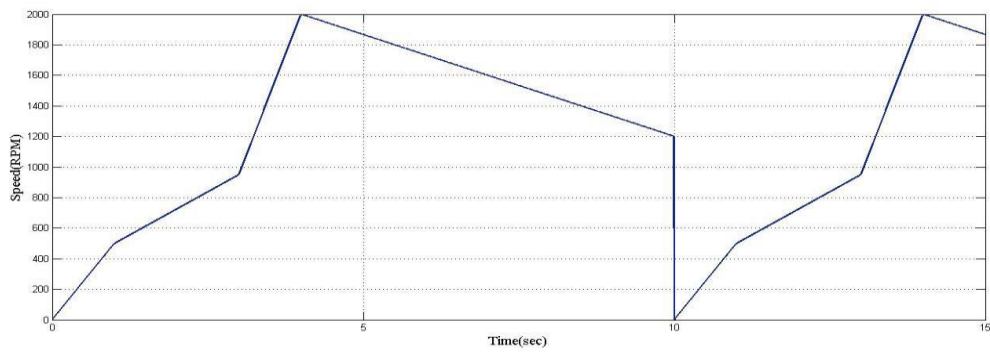

Fig 11 Desired Speed Input

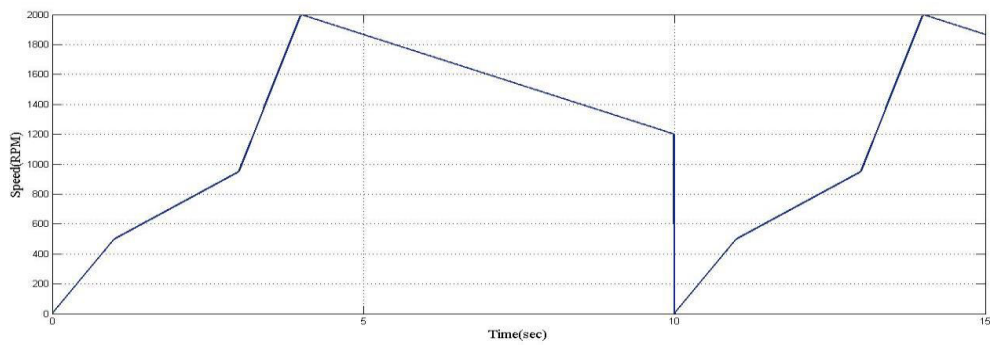

Fig 12 Speed Output of the Vehicle

Fig shows the simulation model for hybrid battery pack and it is too designed with a BMS. The BMS maintains the battery SOC to it's full by recharging and also protects it. The waveforms of voltage and SOC and the vehicle speed are shown in fig 5.3.a, 5.3.b, 5.3.c and 5.3.d respectively.

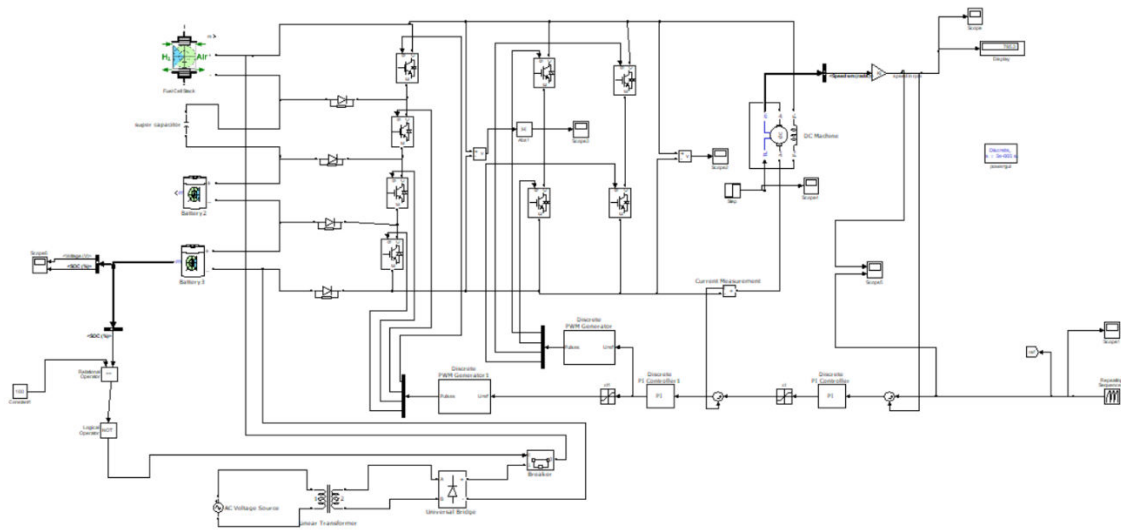

Fig 13 Proposed circuit configuration for Hybrid Model

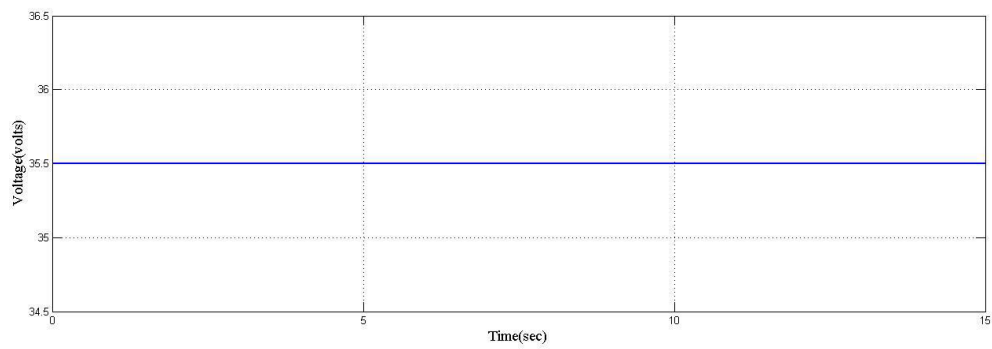

Fig 14 Voltage of Battery in Hybrid Model with BMS

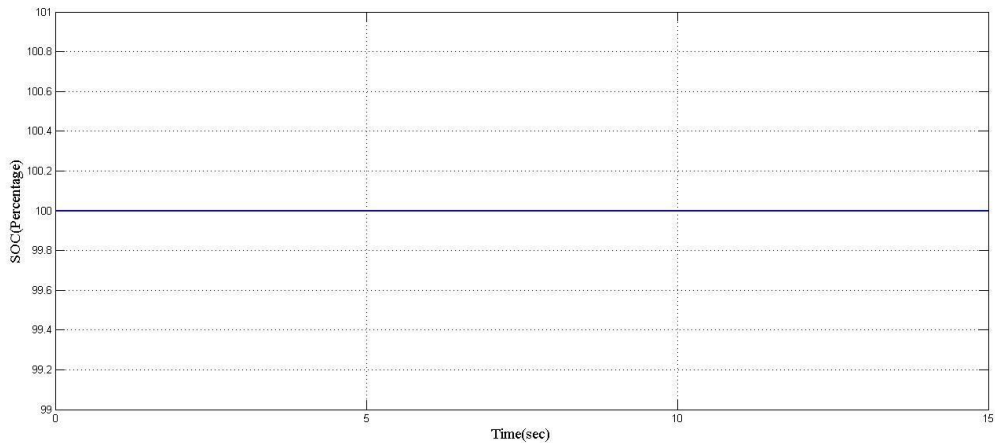

Fig 15 SOC of Battery in Hybrid Model with BMS

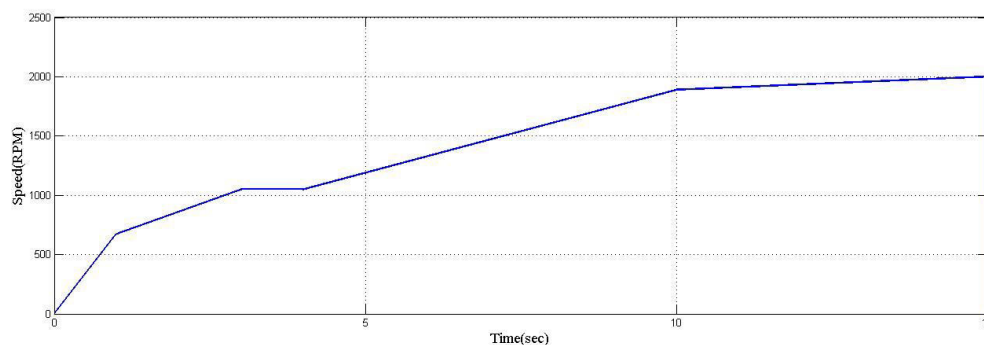

Fig 16 Desired Speed in Hybrid Model

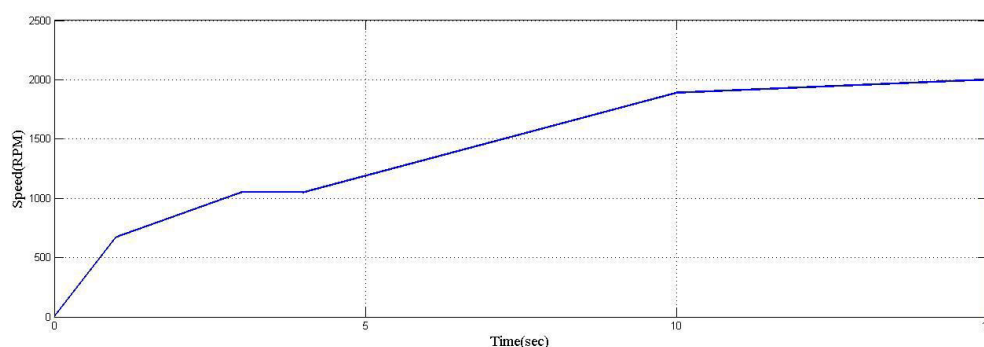

Fig 17 Output Speed in Hybrid Model

CONCLUSION

In conclusion, the design and development of an advanced Battery Pack Management System (BMS) for electric scooters has proven effective in addressing key challenges associated with battery safety, efficiency, and lifespan. Through precise monitoring of parameters such as state-of-charge (SOC), cell balancing, and thermal management, the proposed BMS offers robust protection and optimization for the battery pack. Experimental results indicate that the system significantly reduces risks of overcharging, overheating, and deep discharge, thereby enhancing operational safety and energy efficiency. The incorporation of real-time diagnostics and control algorithms ensures that the BMS adapts to varying usage conditions, prolonging battery life and supporting sustainable electric mobility. This work contributes to the growing field of electric vehicle battery management by providing a practical, scalable solution that can be further refined with emerging technologies like machine learning to meet evolving demands in urban electric transportation.

REFERENCES

1. Kristaps Vitols and Eizens Poiss Development of Electric Scooter Battery Management System in 2018 IEEE 59TH International Scientific Conference on Power and Electrical Engineering of Riga Technical University (RTU CON).
2. Mohammad Saad Alam Graduate Student Member Tanem Taher Student Member IEEE Mohammad Khader Abdul Lateef Riza Kizilel Analysis and Hardware Development of a Novel Prototype Hybrid PEM Fuel Cell Lilon Battery Scooter in 2016 IEEE conference on Electric and Hybrid Vehicles.
3. Noshirwan. K. Medora Alexander Kusko Battery Management for hybrid electric vehicles using super capacitors as a supplementary energy storage system in Intelec 2012.
4. Yegin Wang Yixing Liu Electronic control system design and test of pure electric vehicle battery management system in 2011 Second International Conference on Mechanic Automation and Control Engineering.
5. Hirofumi Akagi Shinichi Kinouchi and Yuji Miyazaki Bidirectional Isolated Dual – Active –

- Bridge (DAB) DCDC Converters Using 1.2 KV 400A SiC MOSFET Dual Modules CPSS Trans. on Power Electronics and Applications vol. 1 no.1 pp. 3340 December 2016.
6. LungSheng Yang and TsorngJuu Liang 2012 Analysis and Implementation of a Novel Bidirectional DCDC Converter IEEE Trans. on Industrial Electronics vol. 59 no. 1 pp. 422434 January 2012.
7. Fan Zhang Xu Zhang Min Zhang Abigail S. E. Edmonds Literature Review of Electric Vehicle Technology and its Applications 5th Inter.Conf. on Computer Science and Network Technology (ICCSNT) 2016 pp. 832837.
8. Jorge Varela BarrerasCl'audio Pinto Ricardo de Castro Erik SchaltzSørenJuhlAndreasen Peter Omand Rasmussen and RuiEstevesAra'ujo Evaluation of a Novel BEV Concept Based on Fixed and Swappable Lilon Battery Packs IEEE Trans. on Industry Applications vol. 52 no. 6 NovemberDecember 2016.
9. Dr. Rateb H. Issa Separately Excited DC Motor Optimal Efficiency Cotroller International Journal of Engineering and Innovative Technology (IJEIT) Vol. 3 pp. 533539 July 2013.
10. Ubaid Bashir Qureshi and Shiekh Javaid Iqbal Development of Wind Turbine Simulator using Separately Excited DC Motor for Induction Generator Testing IEEE 2016.
11. K.Shreelekha and S.Arulmozhi Multiport Isolated Bidirectional DCDC Converter Interfacing Battery and Supercapacitor For Hybrid Energy Storage Application In International Conference on Electrical Electronics and Optimization Techniques (ICEEOT) IEEE 2016 pp. 27632768.
12. Udupi R. Prasanna Anant Kumar Singh and KaushikRajashekara Novel bidirectional SinglephaseSingleStage Isolated ACDC Converter With PFC for Charging of Electric Vehicles IEEE Trans. on Transportation Electrificationvol. 3 no. 3 pp. 536544 2017.
13. Amir TokicAdmirJukan and JasminSmajic 2016 Parameter Estimation of SinglePhaseRectifierBased Loads Analytical Approach IEEE Trans. on Power Delivery. IEEE Trans. on Power Delivery vol. 31 pp. 532540 April 2016.
14. M. H. Rashid Power Electronics Circuits Devices and Applications 3rd Edition 2004.
15. Ali Emadi Young Joo Lee and KaushikRajashekara Power Electronics and Motor Drives in Electric Hybrid Electric and Plug – In Hybrid Electric Vehicles IEEE Trans. on industrial electronics vol. 55 no. 6 june 2008.
16. I. M. Oise U. H. Diala G. N. Ezeh and R. Opara Evaluation of Transient Response of a Separately Excited DC Motor under NoLoad Condition IEEE International Conference on Emerging & Sustainable Technologies for Power & ICT in a Developing Society (NIGERCON) 2013.
17. Zhen Zhang and KwokTongChauPulseWidth–ModulationBased Electromagnetic Interference Mitigation of Bidirectional Grid Connected Converters for Electric Vehicles IEEE Trans. on Smart Grid Vol. 8 No. 6 November 2017.
18. Sivadas .M .C and Poorani Shivkumar Comprehensive Analyses and Comparison of 1kw Isolated DCDC Converters For Bidirectional Ev Charging Systems International Journal of Pure and Applied Mathematics Vol. 118 no. 20 pp. 313319 2018.
19. V.Mounica and Y.P.Obulesu Hybrid Power Management Strategy with Fuel Cell Battery and Supercapacitor for fuel Economy in Hybrid Electric Vehicle Application MDPI Energies 2022154185.