



FIRE DETECTION USING RASPBERRY PI AND IMAGE PROCESSING

V Naresh Kumar¹, R Arun Kumar²

^{1,2}Assistant Professor

Department Of ECE

Sree Chaitanya College of Engineering, Karimnagar

ABSTRACT

The early warning capability is the main characteristic of the project's image processing-based fire detection system. This system can be installed practically anywhere in retail establishments, public spaces, and commercial structures in order to detect fires. This technique uses a camera to detect flames. As a result, more sensors are not needed to detect fire. This device can be implemented at any remote area where there is a possibility of a fire incident. Image processing is a type of processing in which an input image is transformed into an output image by applying certain procedures. The camera input is processed by the system, and subsequently the CPU processes it to identify flames. Heat signatures and fire illumination patterns are examined in images in order to determine whether a fire is present and to take the necessary action. When it detects fire, the gadget goes into emergency mode and sounds an alarm. also provides information by displaying the system's state on the LCD display. Fire detection systems based on Raspberry Pis can be integrated with emergency services and first responders. This method's two primary advantages are remote monitoring for timely action and information dissemination to the user from anywhere at any time.

5327

DOI Number: 10.48047/nq.2022.20.19.nq99508

Neuroquantology 2022; 20(19):5327-5333

I. INTRODUCTION

1.1 PROJECT OVERVIEW:

The project focuses on developing a fire detection system using image processing techniques and Raspberry Pi 3, along with a camera module, buzzer, and LCD display. The objective is to create an automated and efficient solution for detecting fires based on analysing images captured by the camera. The system utilizes the capabilities of Raspberry Pi 3 as the central processing unit and control unit. It is connected to a camera module, which continuously captures images or video frames of the monitored area. These images are processed using image analysis algorithms to identify fire-related patterns or characteristics.

The image processing techniques employed may include colour-based segmentation, edge detection, or template matching. By evaluating pixel intensity values and applying thresholding techniques, the system can distinguish between normal scenes and potential fire situations. If a fire is detected, the system triggers the buzzer for audible alerts, ensuring that individuals in the vicinity are promptly alerted to the danger. The system also incorporates an LCD display to provide visual feedback and status updates. The LCD screen can display relevant information, such as the fire detection status, alarm activation, or evacuation instructions. This enhances the user interface and ensures that



users have real-time information regarding the fire situation.

The image processing-based fire detection system offers several advantages. It provides a quick and automated response to fire incidents, minimizing the risk of property damage and potential harm to individuals. The use of image processing techniques allows for accurate and reliable fire detection, reducing false alarms. The integration of Raspberry Pi 3, camera module, buzzer, and LCD display ensures a comprehensive and user-friendly system.

1.2 MOTIVATION OF PROJECT:

The motivation behind developing an image processing-based fire detection system using Raspberry Pi 3, camera, buzzer, and LCD display stems from the critical need for efficient and timely fire detection in various environments. Fires can pose significant risks to life, property, and the environment, and early detection plays a crucial role in minimizing these risks.

Traditional fire detection systems often rely on smoke or heat sensors, which may not be sufficient in certain scenarios or may lead to false alarms. By leveraging image processing techniques, the proposed system aims to overcome these limitations and provide a more accurate and reliable fire detection solution.

The Raspberry Pi 3, with its computational capabilities and connectivity options, offers a versatile platform for developing advanced fire detection systems. It allows for real-time image processing and analysis, enabling quick and accurate fire detection. The integration of a camera module provides visual information that can be analysed to identify fire-related patterns or characteristics.

The use of image processing techniques allows for the detection of fires based on visual cues, such as colour, texture, and shape, which can improve the accuracy of the system. Additionally, by utilizing Raspberry Pi's capabilities, the system can be easily integrated with other components like a buzzer and LCD display for immediate alerts and visual feedback. The motivation behind this project is to develop a cost-effective and efficient fire detection system that can be deployed in

various environments, including homes, offices, and public spaces. By providing an early warning of fires, the system aims to enhance fire safety measures, facilitate timely evacuation, and reduce the potential for property damage and casualties.

1.3 OBJECTIVES OF PROJECT:

Develop a reliable and accurate fire detection system: The primary objective of the project is to create a fire detection system using image processing techniques that can accurately and reliably detect fires in various environments. The system should be able to analyse captured images and identify fire-related patterns or characteristics with a high degree of accuracy.

Utilize Raspberry Pi 3 and camera module: The project aims to leverage the computational capabilities of Raspberry Pi 3 and the visual data provided by a camera module to perform real-time image processing for fire detection. The objective is to utilize the features and capabilities of these components effectively to create an efficient fire detection system.

Implement image processing algorithms: The project involves implementing and optimizing image processing algorithms for fire detection. These algorithms may include colour-based segmentation, edge detection, or template matching techniques. The objective is to develop robust algorithms that can accurately detect fires while minimizing false alarms.

Integrate a buzzer for audible alerts: An important objective is to integrate a buzzer into the system to provide audible alerts upon fire detection. The buzzer should produce a loud sound to attract attention and prompt immediate action from individuals in the vicinity. Camera Integration:

II. BLOCK DIAGRAM:

5328



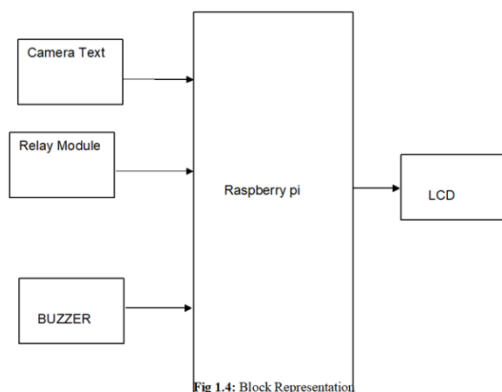

- Raspberry Pi supports the use of camera modules specifically designed for it. These camera modules can capture still images or record videos.
- To integrate the camera with Raspberry Pi, you need to connect it to the dedicated camera connector on the Raspberry Pi board.
- The camera can be controlled and accessed using software libraries and APIs provided by the Raspberry Pi Foundation. Python is commonly used for camera control and image processing tasks.
- Once connected and configured, the camera can capture images or videos of the area being monitored for fire detection.

2. LCD Display:

- An LCD (Liquid Crystal Display) can be connected to the Raspberry Pi to provide visual output and display relevant information.
- The LCD can be connected to the Raspberry Pi's GPIO pins or through other display interfaces such as HDMI or DSI (Display Serial Interface).
- Using appropriate libraries or programming languages like Python, you can control the LCD to display information related to fire detection, such as alerts, sensor readings, or status updates.
- The Raspberry Pi continuously monitors the fire detection system, processes the sensor data, triggers alerts, and updates the LCD display accordingly.

III. LITERATURE SURVEY

The literature survey plays a crucial role in understanding the current state-of-the-art in the field of image processing-based fire

detection systems using Raspberry Pi 3, camera modules, buzzers, and LCD displays. This survey aims to gather and analyze existing research papers, studies, and technical publications that have explored similar projects and technologies. The objective of the literature survey is to gain insights into the methodologies, techniques, and findings of previous works related to image processing-based fire detection systems. By reviewing the literature, the project can identify the challenges, limitations, and opportunities in this area, leading to a more informed and effective design and implementation.

The literature survey begins with an introduction to the project topic, focusing on the use of Raspberry Pi 3 as the core processing unit and the integration of a camera module, buzzer, and LCD display. It then proceeds to explore the existing literature, encompassing research articles, conference papers, and other relevant sources.

The review of the literature entails a critical analysis of the image processing algorithms employed in previous studies for fire detection. This includes techniques such as color-based segmentation, edge detection, and template matching. The survey also examines the performance of different camera modules in capturing fire-related patterns or characteristics accurately.

IV. TECHNICAL DESCRIPTION

4.1 DESCRIPTION :

The image processing-based fire detection project using Raspberry Pi 3, camera modules, buzzers, and LCD displays aims to develop a system that can effectively detect fires in real-time and provide prompt alerts for immediate action. The project utilizes image processing algorithms and hardware integration to create a reliable fire detection solution.

The core component of the system is the Raspberry Pi 3, which acts as the central processing unit. It is responsible for capturing images from the camera module and performing real-time image processing for fire detection. The camera module captures video frames of the environment and feeds them to the Raspberry Pi for analysis.

The image processing algorithms employed in the project are designed to identify fire-related patterns or characteristics within the captured images. Techniques such as colour-based segmentation, edge detection, and template matching may be used to distinguish fire pixels from the background and accurately detect the presence of a fire. These algorithms are implemented and optimized on the Raspberry Pi to ensure efficient processing and real-time performance.

Upon fire detection, the system triggers the buzzer to emit an audible alert. The buzzer serves as an important component for immediate notification, attracting attention and prompting individuals to take necessary actions, such as evacuating the area or contacting emergency services.

In addition to the buzzer, an LCD display is integrated into the system to provide visual feedback and status updates. The LCD display can show real-time information about the fire detection, such as the fire's location or severity. It may also display evacuation instructions or emergency contact details to assist in the response and evacuation process.

4.2 WORKING

The image processing-based fire detection system using Raspberry Pi 3, camera modules, buzzers, and LCD displays follows a specific workflow to detect fires and provide timely alerts. The working process can be summarized as follows:

- **Image Acquisition:** The camera module captures video frames of the environment continuously. These frames are sent to the Raspberry Pi 3 for further processing.
- **Image Pre-processing:** The captured frames may undergo pre-processing steps to enhance image quality and reduce noise. This can include techniques such as resizing, noise filtering, and colour correction to ensure optimal image analysis.
- **Fire Detection Algorithm:** The pre-processed frames are subjected to fire detection algorithms. These algorithms utilize image processing techniques to identify fire-related patterns or characteristics within the frames.

For example, colour-based segmentation techniques can be employed to identify regions with fire-like colours, or edge detection algorithms can be used to detect the boundaries of flames.

- **Fire Verification:** Once potential fire regions are identified, further verification steps may be applied to reduce false positives. This can include analyzing the size, shape, and movement of the detected regions to determine if they correspond to actual fire occurrences.
- **Alert Generation:** When a fire is confirmed, the system triggers the buzzer to emit an audible alert. The buzzer's activation is synchronized with the fire detection event to ensure immediate notification.
- **Visual Feedback:** Simultaneously, the LCD display provides visual feedback by showing relevant information about the fire detection. This can include the location of the fire, its severity, or instructions for evacuation.
- **Alert Management:** The system may incorporate additional features for managing the alerts, such as sending notifications to a remote server or triggering other safety mechanisms like sprinkler systems or emergency lighting.

The system continuously analyses the video frames, performing real-time fire detection and generating alerts as soon as a fire is detected. This enables swift response and intervention, reducing the potential risks and damages caused by fires.

4.3 CIRCUIT DIAGRAM:

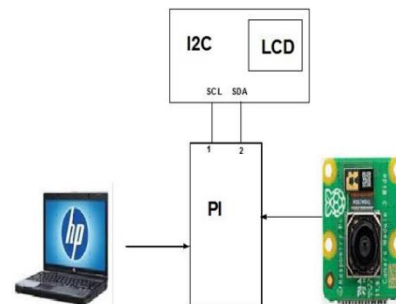

Fig 1: Circuit Diagram

V. RESULT AND CIRCUIT CONNECTIONS

5.1 CIRCUIT DIAGRAM:

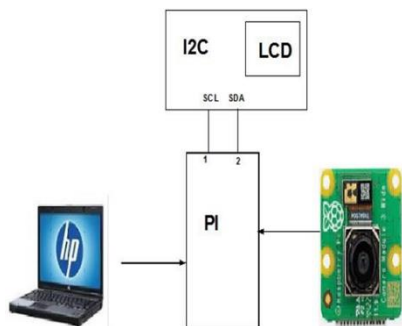

Figure 2 : Circuit Diagram

5.2 RESULT:



Figure 3 Circuit without power supply



Figure 4 Circuit with power supply

5.3 Applications:

1. Home Fire Detection: Raspberry Pi can be utilized to build a cost-effective fire detection system for residential properties. It can integrate with smoke detectors, temperature sensors, and alarms to provide early warnings and trigger appropriate responses.
2. Industrial Fire Monitoring: Raspberry Pi-based fire detection systems can be deployed in industrial settings to monitor critical areas for fire or smoke events. Integration with thermal cameras, gas sensors, and alarm systems can provide enhanced safety measures.
3. Smart Buildings: Raspberry Pi can be part of a smart building infrastructure, where it can monitor multiple areas for fire detection, send alerts to building management systems, and initiate evacuation procedures when necessary.
4. IOT Fire Detection: The combination of Raspberry Pi with Internet of Things (IoT) technologies allows for remote monitoring and control of fire detection systems. Data can be sent to cloud platforms for advanced analytics, historical analysis, and centralized management.

5. Research and Development: Raspberry Pi's flexibility and affordability make it an ideal platform for research and development of new fire detection algorithms, techniques, and sensor integrations.

5.4 Advantages:

1. Cost-Effective Solution
2. Customization and Flexibility
3. Connectivity: Raspberry Pi boards come with built-in networking capabilities, such as Wi-Fi and Ethernet, allowing for easy integration into existing networks. This connectivity enables real-time data transmission, notifications, and remote monitoring.
4. Integration with Sensors
5. Data Processing and Analysis

5.5 Disadvantages:

1. Processing Limitations: Raspberry Pi boards have finite processing power compared to dedicated fire detection systems. Complex algorithms or large-scale data processing may strain the device, potentially affecting real-time detection and response.
2. Reliability: As Raspberry Pi is a general-purpose computing platform, its reliability for critical applications, such as fire detection, might be a concern. System stability, power supply, and environmental factors need to be carefully managed to ensure consistent operation.
3. Limited Scalability: While Raspberry Pi can handle small-scale fire detection systems effectively, scaling up to larger installations may present challenges. Coordinating multiple Raspberry Pi devices and managing the network infrastructure can be more complex compared to dedicated fire detection systems.

VI. CONCLUSION AND FUTURE SCOPE

6.1 CONCLUSION:

In conclusion, using a Raspberry Pi for fire detection offers a flexible and reasonably priced solution for a variety of applications. Cost, flexibility, connectivity, and the ability to manage data and integrate with sensors are among the advantages. It has less computer power, is less scalable, and is less dependable than specialized fire detection systems.

For IoT integration, smart building, industrial monitoring, home fire detection, and research, Raspberry Pi can be a useful platform. It makes remote monitoring possible, integration with existing infrastructure possible, and the development of personalized fire detection systems possible. However, careful consideration should be given to the specific requirements of the application as well as the criticality of the fire detection system to ensure that the Raspberry Pi's capabilities meet the necessary functionality and reliability for the task.

Ultimately, the decision to utilize a Raspberry Pi for fire detection is based on several factors, including as the dependability of the application, the need for customisation, the need for scalability, and cost. You can determine whether the Raspberry Pi is the best choice for your fire detection project by weighing the advantages and disadvantages.

6.2 FUTURE APPLICATIONS

- **Advanced Sensor Integration:** As sensor technology continues to progress, Raspberry Pi-based fire detection systems can benefit from the integration of more complex and specialized sensors. The utilization of sophisticated smoke detectors, gas sensors, thermal cameras, and even AI-powered image recognition algorithms are all used to increase the accuracy and efficiency of fire detection.
- **AI and machine learning:** The performance of fire detection systems can be significantly enhanced by the introduction of AI and machine learning techniques. Machine learning models that will be used to detect fire patterns, identify potential fire hazards, and improve the overall effectiveness and accuracy of fire detection algorithms can be trained and implemented on a Raspberry Pi.
- **Cloud Integration and Data Analytics:** As cloud computing and big data analytics grow more popular, Raspberry Pi-based fire detection systems can benefit from using cloud platforms to store and analyze data. This allows real-time monitoring, historical analysis, predictive modeling, and centralized management of several fire detection sensors.

- **IOT Connectivity and Smart Automation:** By integrating with the Internet of Things (IOT), Raspberry Pi-based fire detection systems can establish communication with other smart devices and building management systems. Automated processes like activating emergency protocols, closing fire doors, and turning on sprinkler systems may be coordinated and efficient thanks to this communication.

- **Wireless Sensor Networks:** Bluetooth, Zigbee, or Lora wireless communication technologies, along with a Raspberry Pi, can be used to create wireless sensor networks for fire detection. This allows for the installation of scattered sensors in remote locations or large areas, providing comprehensive coverage and real-time data delivery.

- **Better User Interfaces and Visualizations:** With enhanced graphical user interfaces (GUIs) and visualization capabilities, users can monitor and comprehend fire detection data more easily. The Raspberry Pi can be used to build user-friendly interfaces that allow people to interact with the fire detection system, send out alarms, and display sensor readings in real time.

- **Integration with Emergency Services:** Fire detection devices based on Raspberry Pis can notify emergency services and first responders. Real-time data interchange and automated notifications can improve situational awareness, coordination, and reaction times during fire incidents.

REFERENCES:

- Hui, X., Xiang, S., & Peng, Z. (2016). Fire Detection Algorithm Based on Image Processing. In 2016 2nd IEEE International Conference on Computer and Communications (ICCC) (pp. 40-43).IEEE.
- Wu, J., Wen, G., Li, D., & Li, Y. (2017). Research on Fire Detection Algorithm Based on Image Processing Technology. In 2017 13th International Conference on Computational Intelligence and Security (CIS) (pp. 263-266).IEEE.
- Jain, V., & Kansal, R. (2018). Fire Detection and Alert System Using Raspberry Pi. In 2018 International Conference on Current Trends



towards Converging Technologies (ICCTCT) (pp. 1-5). IEEE.

- Rajalakshmi, N., & Raghavendra, R. (2015). Fire Detection Using Image Processing. International Journal of Innovative Research in Electrical, Electronics, Instrumentation and Control Engineering, 3(5), 46-50.
- Shih, H. C., Chen, S. J., & Huang, C. H. (2017). A Fire Detection System Based on Raspberry Pi and Machine Learning. In 2017 IEEE 2nd International Conference on Cybernetics (CYBCONF) (pp. 1-6).

