

Controlling Synchronization of Modified FitzHugh-Nagumo Neurons Under External Electrical Stimulation

Deepak Mishra, Abhishek Yadav, Sudipta Ray and Prem K. Kalra

Abstract

We report control of synchronization between pair of coupled neurons under external electrical stimulation. A nonlinear controlling mechanism is proposed for keeping the coupled system in synchronized state. We studied transitions between synchrony and asynchrony because of variation in coupling strength. We discuss the dynamical analysis for the Modified FitzHugh-Nagumo neuron model in detail. This work focuses the application of control system theory for understanding possible synchronization phenomena in a pair of biological neuron models.

Key Words: modified FitzHugh-Nagumo, nonlinear controller, synchronization, coupled neurons

NeuroQuantology 2006; 1: 50-67

Introduction

Determining the dynamical behavior of an ensemble of coupled neurons is an important problem in computational neuroscience. Commonly used models for the study of individual neuron which display spiking behavior include (a) Integrate-and-Fire neuron model and its variants (b) FitzHugh-Nagumo model (c) Hodgkin-Huxley model and (d) Morris-Lecar model (Gerstner, 2002; FitzHugh, 1969; Nagumo, 1962; Hodgkin, 1952; Koch, 1999; Abbott, 2001). From the very beginning of the research in the field of computational neuroscience, people deal with single neuron and its behavior. Present trends of research include investigation of

Corresponding authors: Department of Electrical Engineering, Indian Institute of Technology Kanpur, India,
e-mail: dkmishra@iitk.ac.in, ayadav.iitk@gmail.com, sray@iiita.ac.in, kalra@iitk.ac.in

the behavior of neurons considered in a network and their way to fire synchronously. It is assumed that the activities in the brain are synchronous and underlying interests for synchronization of nonlinear oscillators in physical and biological systems range from novel communication strategies to understand how large and small neural assemblies efficiently and sensitively achieve desired functional goal (Pinto, 2000).

The dynamics of many neural ensembles such as central pattern generators or thalamo-cortical circuits poses questions related to the cooperative behavior of neurons. Each neuron independently may show irregular behavior while ensembles of different neurons can synchronize in order to process biological information or produce regular, rhythmic activity (Elson, 1999). How do the dissimilar neurons synchronize? How do they inhibit noise and intrinsic fluctuations? What are the parameters responsible for such synchronization and regularization? Answers to these and similar questions may be found through simulations and experiments that enable one to follow qualitatively the cooperative dynamics of neurons as intrinsic synaptic parameters are varied (Elson, 1999). However, these problems did not receive many opportunities for extensive study. Many cells are linked together by specialized inter-cellular pathways known as gap junction. There are two types of possible couplings among neurons namely weak coupling and strong coupling, defined on the basis of the magnitude of coupling strength. In my paper (Mishra, 2004), the effect of coupling strength on dynamics of coupled neurons is studied.

In recent years, there has been tremendous interest for the study of the synchronization of chaotic systems. The synchronous and asynchronous behavior of neurons is one of the important research topics (Jiang, 2004; Thompson, 1999). Application of nonlinear active controller for maintaining synchronism among neurons is one of the issues addressed in (Ucar, 2004). The phenomenon of synchronism gives rise to different dynamical behaviors such as chaotic synchronization etc. In (Mishra, 2004; Mishra, 2005), nonlinear dynamical analysis on single and coupled modified FitzHugh-Nagumo model under steady current stimulation is carried out. Also the effect of parameter variation on its behavior is investigated.

In many papers (Pinto, 2000; Ucar, 2004; Rinzel, 1987; Elson, 1999) dynamical analysis on various neuron models is carried out under steady current input. The variations

in the external stimulus may bring the system to unstable state from a stable one. However, biological rhythms, such as, cardiac and circadian rhythms arise from activity of multiple oscillators with dispersed intrinsic frequencies (Chang, 2000). Variety of complex dynamical behavior including phase locked limit cycles, quasi-periodicity, intermittency and chaos are observed in literature (Thompson, 1999) for sinusoidal external fields. Chang *et.al.* (Chang, 2000), investigated the stability of the output rhythm of these sympathetic oscillators for a periodic driving force.

In this paper, a nonlinear controller has been designed to synchronize a coupled modified FitzHugh-Nagumo model. Dynamical characteristics of modified FitzHugh-Nagumo neuron model under external stimulation are discussed first. With the variation of the stimulation and the initial condition, the complex behavior is revealed. The response of a model of two neurons coupled with a gap junction is investigated and the significance of coupling coefficient is studied next. We propose a nonlinear active controller for the synchronization of a pair of coupled neurons. Numerical results in support of our findings are also presented. At last, we conclude our work.

Dynamics of Modified FitzHugh-Nagumo Neuron Model

The modified FitzHugh-Nagumo equations are a set of three coupled differential equations which exhibit the qualitative behavior observed in neurons, viz quiescence, excitability and periodicity (Rinzel, 1987). The system can be represented as

$$\begin{aligned}\dot{x} &= x - x^3 / 3 - w + y + F(t) \\ \dot{w} &= f(x + a - bw) \\ \dot{y} &= e(-x + c - dy)\end{aligned}\tag{1}$$

Where, $F(t) = (A / \Omega) \cos(\Omega t)$

The function $F(t)$ represents the external stimulus. The variable x represents the potential difference between the dendritic spine head and its surrounding medium, w is recovery variable and y represents the slowly moving current in the dendrite. In this

model, x and w together make up a fast subsystem relative to y . The Jacobian at equilibrium point (x^*, w^*, y^*) is found to be

$$J = \begin{bmatrix} 1-x^2 & -1 & 1 \\ f & -bf & 0 \\ -e & 0 & -ed \end{bmatrix} \quad (2)$$

If at a neighborhood of a particular value m_0 of the parameter m , there exists a pair of eigenvalues of $J(m)$ of the form $a(m) \pm ib(m)$ such that $a(m) = 0, b(m) \neq 0$, then no other eigenvalue of $J(m_0)$ will be an integral multiple of $ib(m_0)$. Thus $J(m_0)$ has a pair of pure imaginary eigenvalues. This helps in understanding the dynamics of the model at the equilibrium point.

Dynamics of Single Uncoupled Modified FitzHugh-Nagumo Neuron Model

The dynamical set of equations of a single uncoupled modified FitzHugh-Nagumo system is given in equations (1). The system parameters used for simulations are $a = 0.7, b = 0.8, c = -0.775, f = 0.08, e = 0.0001$ and $d = 1.0$. The calculated equilibrium point for the system at $F(t) = 0$ is: $(x^*, w^*, y^*) = (-1.0292, -0.4115, 0.2542)$. Eigenvalues at these points are: $(\lambda_1, \lambda_2, \lambda_3) = (-0.0002, -0.061+j0.283, -0.061+j0.283)$.

We found that the set of equations are asymptotically stable around the equilibrium points at $F(t) = 0$. The variations in the external stimulus bring the system to unstable state (periodic oscillation). We analyze the response of the model by subjecting it under the following electrical stimulation

$$F(t) = (A/\Omega) \cos(\Omega t) \quad (3)$$

Here, A represents the magnitude of the stimulus and Ω refers to the frequency of given stimulus. The stimulus frequency is varied while keeping the magnitude at a fixed value of $A = 0.71$, since at this particular value of A , modified FitzHugh-Nagumo neuron model gives periodic spiking. Simulation results at different stimulus frequencies are shown in Figure 1 and Figure 2. Time response for the neuron at $\Omega = 0.07$ is shown in Figure 1(a) and phase portrait is drawn in Figure 1(b). Similar responses for $\Omega = 0.127$ are shown in Figure 2. It is observed that with the variation in stimulus frequency, the neuron shows

complex chaotic behavior. Hence the stimulus frequency can be considered as a significant parameter that affects the behavior of neuron.

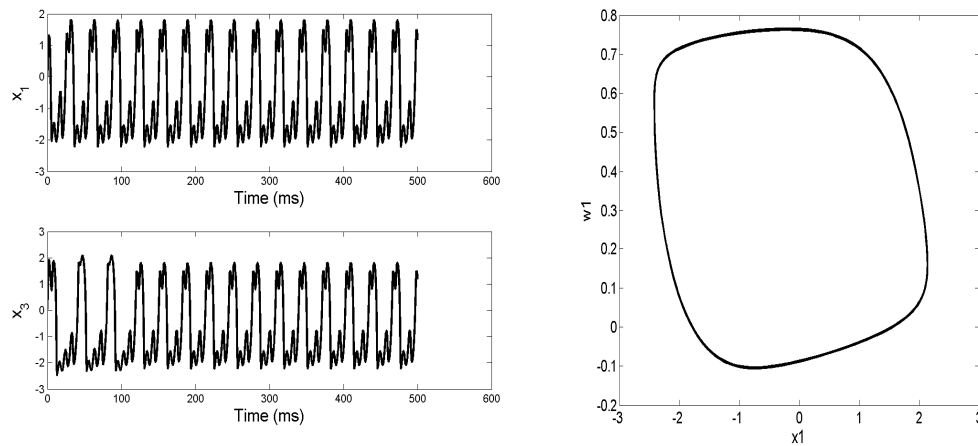

Fig.1 Time responses and phase portrait for modified FitzHugh-Nagumo model at stimulus frequency $W = 0.07$ (a) Time response (b) phase portrait.

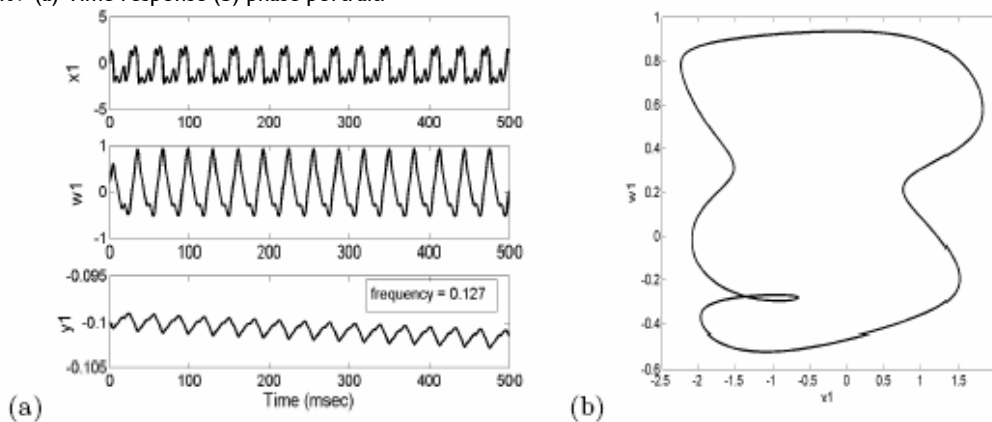

Fig.2 Time responses and phase portrait for modified FitzHugh-Nagumo model at stimulus frequency $W = 0.07$ (a) Time response (b) phase portrait.

Bifurcation analysis with W as the parameter

We have investigated behavioral change in the dynamics of modified FitzHugh-Nagumo model with respect to W by plotting leading Lyapunov exponents, and bifurcation diagram in Figure 3. It is observed that modified FitzHugh-Nagumo model exhibits stable, periodic and chaotic behavior for different value of W . Thus the frequency of injected stimulus plays important role and its variation alters the dynamics of model. The Lyapunov exponent is positive for $W = 0.127$.

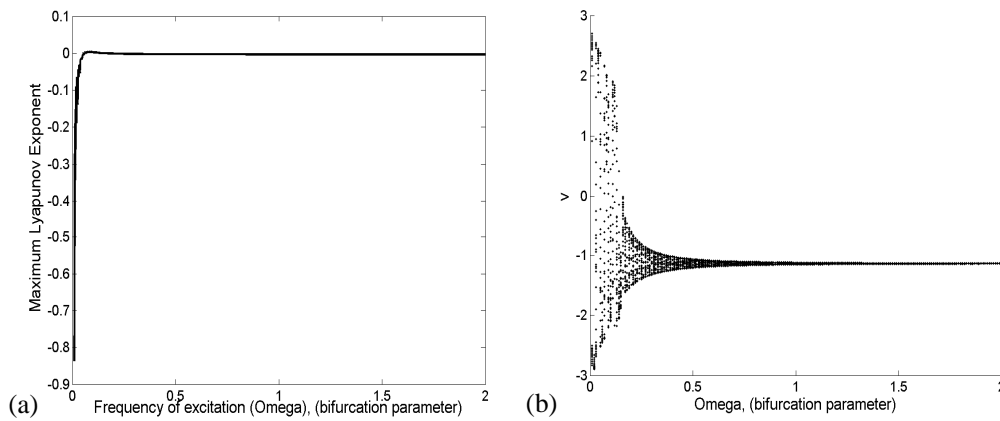

Fig.3 Plots of Leading Lyapunov exponent and bifurcation diagram with W as bifurcation parameter. (a) Leading Lyapunov exponent; (b) Bifurcation diagram.

Dynamics of Coupled Modified FitzHugh-Nagumo Neuron Model

We studied the characteristics of an uncoupled modified FitzHugh-Nagumo neuron in the previous section. In this section, we extend our analysis for coupled neuron models. A system of two coupled neurons can be expressed as:

$$\frac{dX_i}{dt} = f(X_i) + c \arctan(X_j) \quad (4)$$

$i, j = 1, 2 \quad i \neq j$

where $X_{ij} \in \mathbb{R}^n$ (x_i or x_j) represents state variable of the two oscillating neurons, function $f: \mathbb{R}^n \rightarrow \mathbb{R}^n$ defines the dynamics of a single neuron in the absence of coupling, and c is the coupling matrix. Complete synchronization occurs when the coupled chaotic oscillators asymptotically exhibit identical behaviors, i.e., when $\|X_1(t) - X_2(t)\| \rightarrow 0$ as $t \rightarrow \infty$, for any initial condition. The synchronization is dependent on the coupling matrix c . The dynamical equations for the coupled modified FitzHugh-Nagumo neuron model are given in equations (5).

The two systems are coupled with different coupling parameters, say g_c and g'_c , with rest of the parameter values kept identical.

$$\begin{aligned}
 \dot{x}_1 &= x_1 - x_1^3 / 3 - w_1 + y_1 + F(t) + g_c \arctan(x_2) + (A / 2p\Omega) \cos(2p\Omega t) \\
 \dot{w}_1 &= f(x_1 + a - bw_1), \quad \dot{y}_1 = e(-x_1 + c - dy_1) \\
 \dot{x}_2 &= x_2 - x_2^3 / 3 - w_2 + y_2 + F(t) + g'_c \arctan(x_1) + (A / 2p\Omega) \cos(2p\Omega t) \\
 \dot{w}_2 &= f(x_2 + a - bw_2), \quad \dot{y}_2 = e(-x_2 + c - dy_2)
 \end{aligned} \tag{5}$$

We have carried out the analysis in the presence of external electrical stimulus of magnitude $A = 0.7$ and frequency $W = 0.127$, the values for which the model exhibits complex chaotic response.

The results for strongly coupled neuron models are shown in Figure 4. The coupling strengths are: $g_c = 0.9$ and $g'_c = 0.9$. The coupled modified FitzHugh-Nagumo neurons are synchronous, but the response is chaotic. Time courses for the variables x_1 and x_2 are shown in Figure 4(a). The synchronism among the neurons is evident from the plot between x_1 and x_2 , which is almost a straight line as shown in Figure 4(b).

We analyze a loosely coupled neural system, where the values for coupling coefficient are kept as $g_c = 0.009$ and $g'_c = 0.009$. The responses of coupled neurons are asynchronous. The firing of one neuron is out of phase with the other neuron. The time courses for x_1 and x_2 , when system is loosely coupled, are shown in Figure 5(a). Figure 5(b) shows the plot between x_1 and x_2 .

The coupling among neurons can be weak and strong, so we have taken effect of unequal (Weak-Strong) coupling. This is done by keeping one of the neuron in strongly coupled state and other in weakly coupled state i.e. by keeping $g_c = 0.9$ and $g'_c = 0.009$. The response with these values of coupling strengths is shown in Figure 6. The time courses for variables x_1 and x_2 are plotted in Figure 6(a). The responses of the variable x_1 and x_2 are not in complete synchronism but they are trying to achieve a synchronous state. The same can be observed from phase portrait of x_1 and x_2 drawn in Figure 6(b). In this case, neurons try to maintain synchronization, but they are not in exact synchronism. In order to bring this coupled system in synchronism, we need an active controller. In the next section, a control mechanism is explained which keeps the coupled neurons in exact synchronism by applying a control input to one of the pairs of neurons.

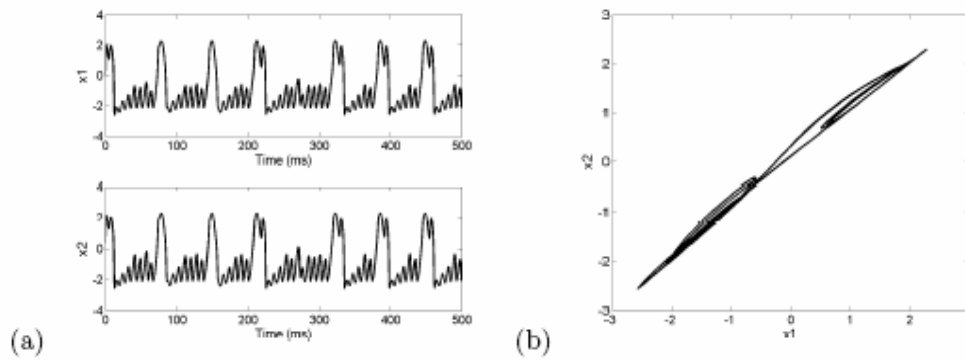

Fig.4 Response of coupled modified FitzHugh-Nagumo neuron models (equations 5) with coupling strengths $g_c = 0.9$ and $g'_c = 0.9$. (a) The time courses for variables x_1 and x_2 (b) Phase portrait of the components of oscillations.

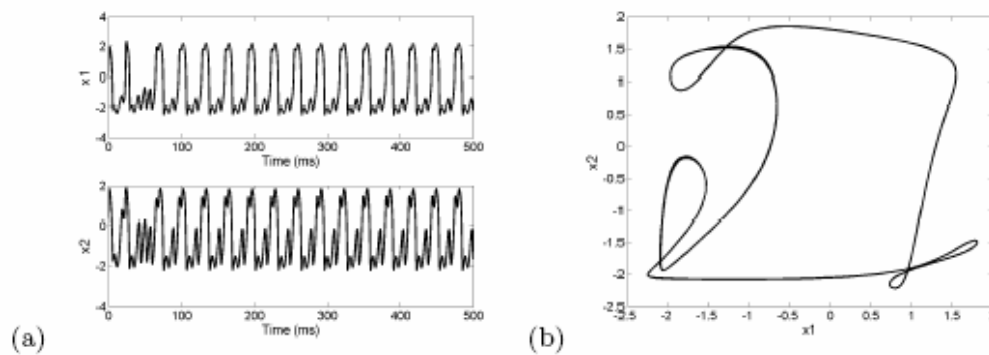

Fig.5 Response of coupled modified FitzHugh-Nagumo neuron models (equations 5) with coupling strengths $g_c = 0.9$ and $g'_c = 0.009$. (a) The time courses for variables x_1 and x_2 (b) Phase portrait of the components of oscillations.

The findings in the analysis of coupling strength effects support the hebbian hypothesis. According to Donald Hebb, if input from neuron A often contributes to the firing of neuron B , then the synapse from A to B should be strengthened (Dyan, 2001). Thus it can be stated that the coupling between the pair of neuron is one of the important parameter to be studied for exploring the intricacies of the coupled system.

Nonlinear Active Controller for a Pair of Coupled Modified FitzHugh-Nagumo System

It is found in previous section that because of unequal coupling strength we observe asynchrony among pair of neurons. In this section, we propose a control mechanism which can bring the two systems into exact synchronism. The schematic diagram for two coupled neurons is shown in Figure 7. The method is based on the Lyapunov stability theory.

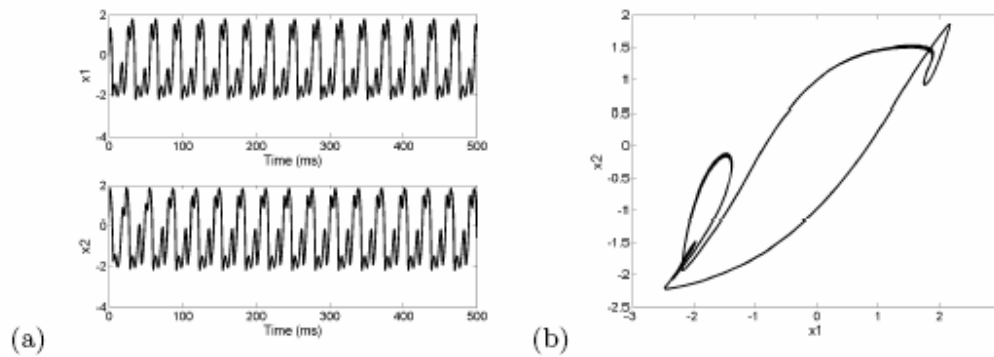

Fig.6 Response for coupled modified FitzHugh-Nagumo neuron model (equations 5) with coupling strengths $g_c = 0.009$ and $g'_c = 0.009$. (a) The time courses for variable x_1 and x_2 (b) Phase portrait of the components of oscillations.

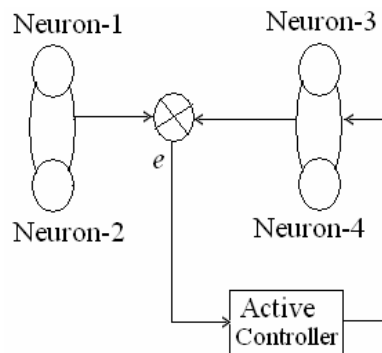

Fig. 7 Schematic diagram of two coupled neurons controlled by an active controller.

Responses for Uncontrolled Pair of Neurons

To begin with, we show the results for two uncontrolled coupled pairs of neurons whose dynamical equations can be given by the following set of equations.

$$\begin{aligned} \dot{x}_1 &= x_1 - x_1^3/3 - w_1 + y_1 + F(t) + g_c \arctan(x_2) + (A/2p\Omega) \cos(2p\Omega t) \\ \dot{w}_1 &= f(x_1 + a - bw_1), \quad \dot{y}_1 = e(-x_1 + c - dy_1) \end{aligned} \tag{6}$$

$$\begin{aligned} \dot{x}_2 &= x_2 - x_2^3/3 - w_2 + y_2 + F(t) + g'_c \arctan(x_1) + (A/2p\Omega) \cos(2p\Omega t) \\ \dot{w}_2 &= f(x_2 + a - bw_2), \quad \dot{y}_2 = e(-x_2 + c - dy_2) \end{aligned}$$

$$\begin{aligned} \dot{x}_3 &= x_3 - x_3^3/3 - w_3 + y_3 + F(t) + n_c \arctan(x_4) + (A/2p\Omega) \cos(2p\Omega t) \\ \dot{w}_3 &= f(x_3 + a - bw_3), \quad \dot{y}_3 = e(-x_3 + c - dy_3) \end{aligned} \tag{7}$$

$$\begin{aligned} \dot{x}_4 &= x_4 - x_4^3/3 - w_4 + y_4 + F(t) + n'_c \arctan(x_3) + (A/2p\Omega) \cos(2p\Omega t) \\ \dot{w}_4 &= f(x_4 + a - bw_4), \quad \dot{y}_4 = e(-x_4 + c - dy_4) \end{aligned}$$

The parameters used for the uncontrolled coupled pair of neurons are same as used for earlier analysis. The only changes are in the values of coupling coefficients. The coefficient values used are: $g_c = g'_c = 0.6$ and $n_c = n'_c = 0.02$. Simulation results for this model are drawn in Figure 8. The time evolutions of the variables x_1 and x_3 are shown in Figure 8(a). The corresponding phase portrait between x_1 and x_3 is plotted in Figure 8(b). Error curves for uncontrolled system are plotted in Figure 9. It is evident from these figures that the pairs of neurons are in asynchronous state.

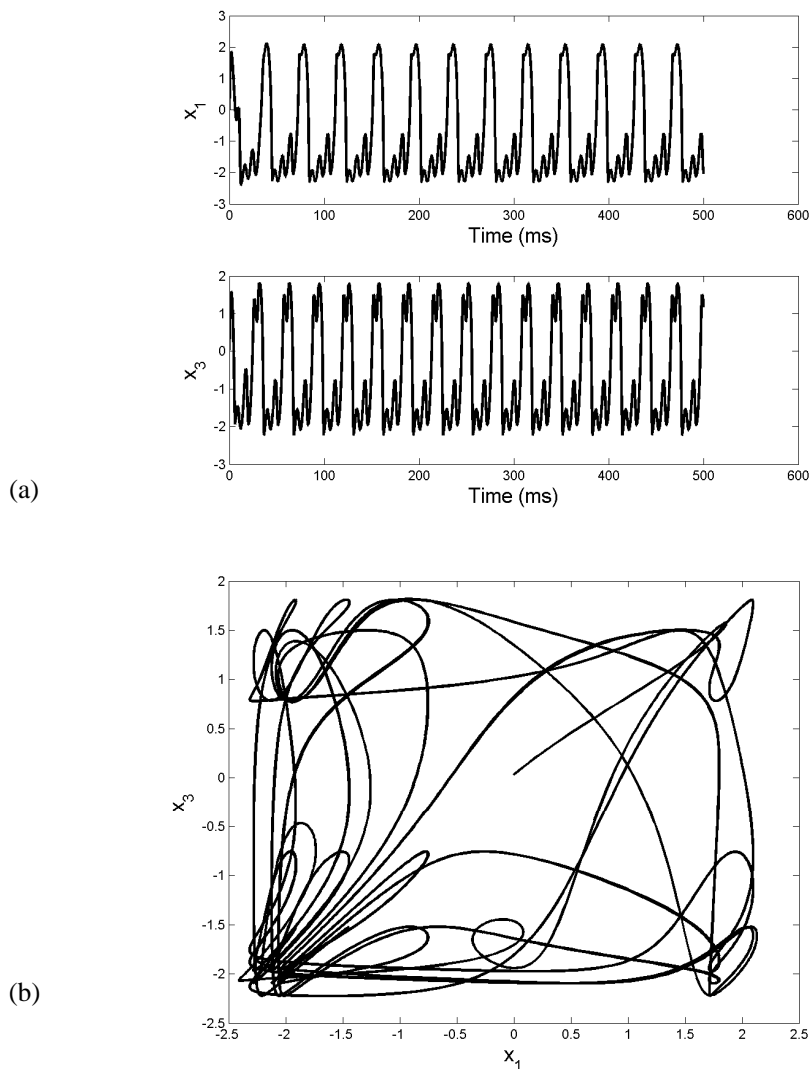

Fig.8 Responses of pair of coupled neurons (equations 6 and 7) used in the absence of nonlinear active controller at different coupling strengths $g_c = 0.6$ and $n_c = 0.02$. (a) Time courses for variables x_1 and x_3 (b) Phase portrait of the components of oscillations

Responses for controlled pair of neurons

In order to bring the synchronism among these neurons we proposed a control law. The equations given in (7) are replaced by the set of coupled system given by equations (8), which incorporates the control input. Thus,

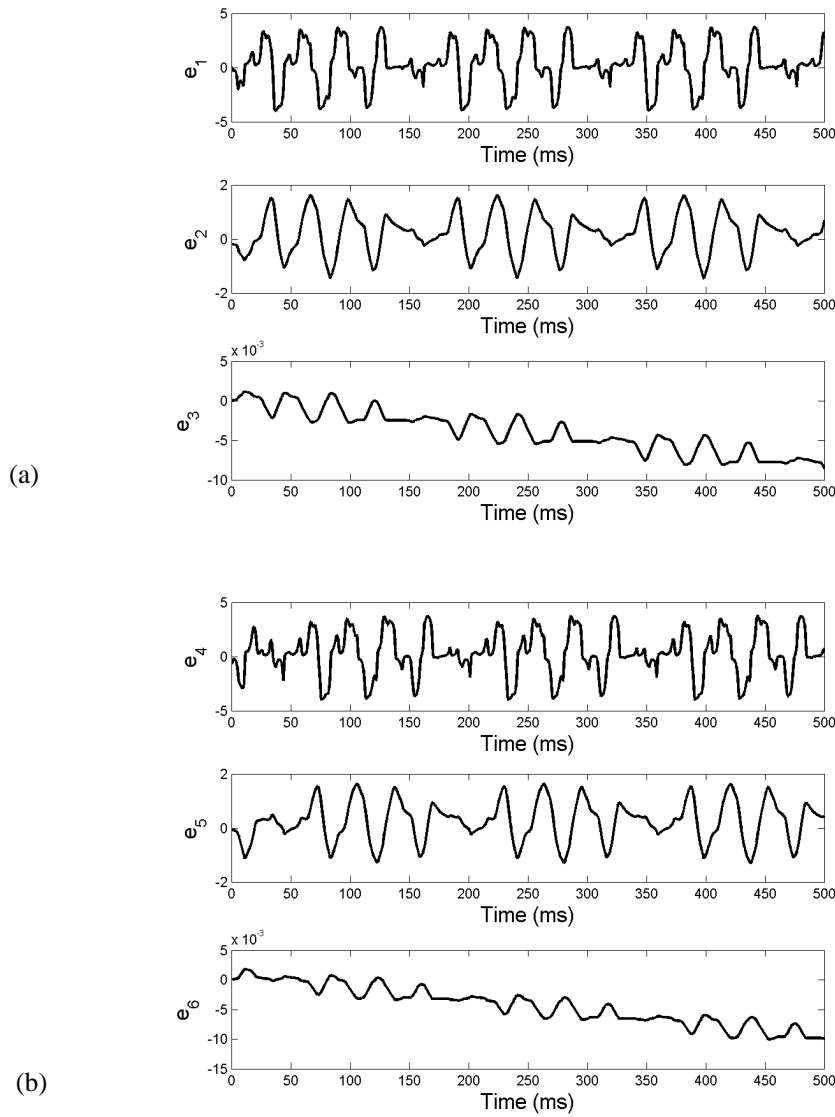

Fig. 9 The error curves for the variables in modified FitzHugh-Nagumo system (equations 6 and 7) at coupling strengths $g_c = 0.6$ and $g'_c = 0.02$. (a) Error signals e_1 , e_2 and e_3 (b) Error signals e_4 , e_5 and e_6 .

$$\begin{aligned} \dot{x}_3 &= x_3 - x_3^3/3 - w_3 + y_3 + F(t) + n_c \arctan(x_4) + (A/2p\Omega) \cos(2p\Omega t) + m_a(t) \\ \dot{w}_3 &= f(x_3 + a - bw_3) + m_b(t), \quad \dot{y}_3 = e(-x_3 + c - dy_3) + m_c(t) \\ \dot{x}_4 &= x_4 - x_4^3/3 - w_4 + y_4 + F(t) + n'_c \arctan(x_3) + (A/2p\Omega) \cos(2p\Omega t) + m_d(t) \\ \dot{w}_4 &= f(x_4 + a - bw_4) + m_e(t), \quad \dot{y}_4 = e(-x_4 + c - dy_4) + m_f(t) \end{aligned} \quad (8)$$

Errors between the variables are calculated as

$$\begin{aligned} e_1 &= x_3 - x_1, e_2 = w_3 - w_1, e_3 = y_3 - y_1 \\ e_4 &= x_4 - x_2, e_5 = w_4 - w_2, e_6 = y_4 - y_2 \end{aligned} \quad (9)$$

Ideally, the rate of change of error must be zero in order to achieve exact synchronism.

Derivative of the error signals are given by

$$\begin{aligned} \dot{e}_1 &= \dot{x}_3 - \dot{x}_1, \dot{e}_2 = \dot{w}_3 - \dot{w}_1, \dot{e}_3 = \dot{y}_3 - \dot{y}_1 \\ \dot{e}_4 &= \dot{x}_4 - \dot{x}_2, \dot{e}_5 = \dot{w}_4 - \dot{w}_2, \dot{e}_6 = \dot{y}_4 - \dot{y}_2 \end{aligned} \quad (10)$$

The calculated error signal for the system is given by following equations

$$\begin{aligned} \dot{e}_1 &= e_1 - e_3 + e_2 - x_3^3/3 + x_1^3/3 + n_c \arctan(x_4) - g_c \arctan(x_2) + m_a \\ \dot{e}_2 &= f(e_1 - be_3) + m_b, \quad \dot{e}_3 = e(-e_1 - de_2) + m_c \\ \dot{e}_4 &= e_4 - e_5 + e_6 - x_4^3/3 + x_2^3/3 + n'_c \arctan(x_3) - g'_c \arctan(x_1) + m_d \\ \dot{e}_5 &= f(e_4 - be_5) + m_e, \quad \dot{e}_6 = e(-e_4 - de_6) + m_f \end{aligned} \quad (11)$$

We proposed the control law for m_a , m_b , m_c , m_d and m_f in equations (12). They are expressed as in equation (12).

$$\begin{aligned} m_a &= -Ke_1 + e_2 - e_3 + x_3^3/3 - x_1^3/3 - n_c \arctan(x_4) + g_c \arctan(x_2) \\ m_b &= -fbe_1, \quad m_c = ede_1 \\ m_d &= -K_1e_4 + e_5 - e_6 + x_4^3/3 - x_2^3/3 - n'_c \arctan(x_3) + g'_c \arctan(x_1) \\ m_e &= -fbe_5, \quad m_f = ede_6 \end{aligned} \quad (12)$$

The systems given in (6) and (8) will approach synchronization for any initial conditions by the control law given by (12). We construct the Lyapunov function

$$V = (1/2)(e_1^2 + e_2^2 + e_3^2 + e_4^2 + e_5^2 + e_6^2) \quad (13)$$

The differential of the Lyapunov function along the trajectory of system (11) is

$$\dot{V} = \dot{e}_1 e_1 + \dot{e}_2 e_2 + \dot{e}_3 e_3 + \dot{e}_4 e_4 + \dot{e}_5 e_5 + \dot{e}_6 e_6 \quad (14)$$

Substituting above into (14) results in

$$\dot{V} = (-e_1^2 - e_2^2 - e_3^2 - e_4^2 - e_5^2 - e_6^2) < 0 \quad (15)$$

which gives asymptotic stability of the system by Lyapunov stability theory. This means that the coupled systems (6) and (8) are synchronized for any initial conditions.

Results of the controlled pair of coupled modified FitzHugh-Nagumo neurons are shown in Figure 10. The time evolutions of variables x_1 and x_3 are shown in Figure 10(a). Phase portrait for variables x_1 and x_3 is plotted in Figure 10(b). It is evident that the set of coupled neurons is now in exact synchronism. The control signal profile is shown in Figure 11. This shows the time evolution of controller activity. The error profile drawn for the system is shown in Figure 12. The system is operated without any controller till $t=250$ msec and it is switched to controlling mode after this time instant. It is observed from the error profile that, as soon as the controller comes into action, system achieves complete synchronism.

The description of a nonlinear controller for maintaining synchronism is given. We compared the results with a nonlinear coupled neuron model in the absence of controlling mechanism. It is found that the application of active controller for maintaining synchronism in nonlinear systems is very effective and can be used in real life applications.

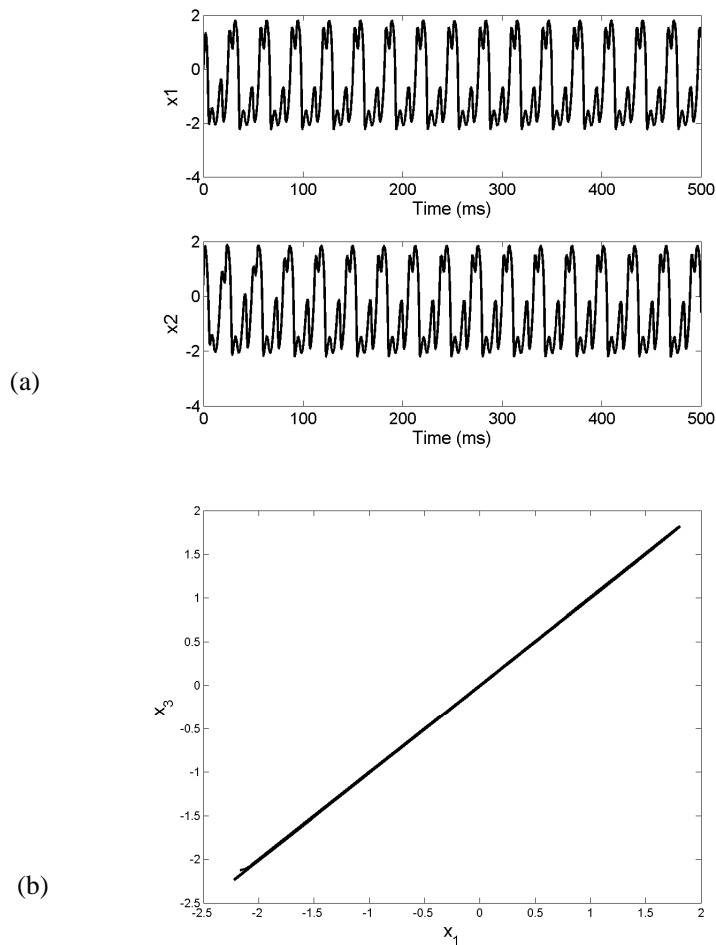

Fig. 10 Responses of pair of coupled neurons (equations 6 and 8) with nonlinear active controller. The responses are generated at different coupling strengths i.e. $g_c = 0.6$ and $n_c = .02$. (a) Time courses for variables x_1 and x_3 (b) Phase portrait of the components of oscillations.

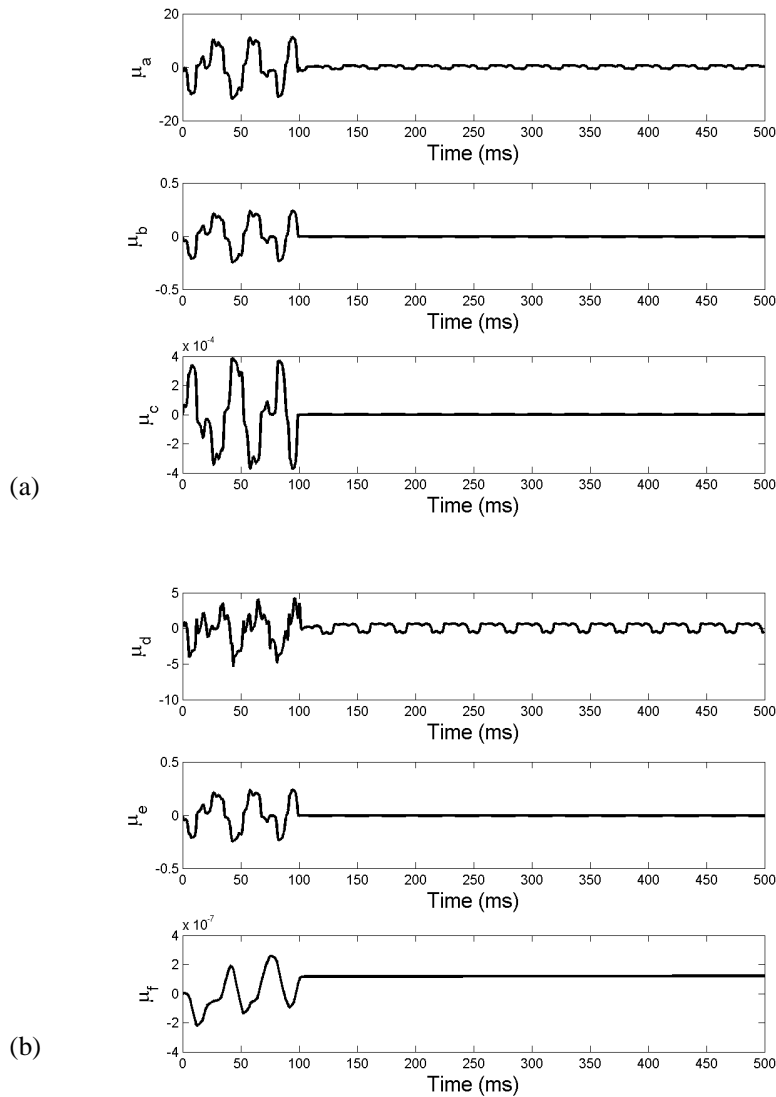

Fig. 11 Responses of pair of coupled neuron used with nonlinear active controller at different coupling strengths $g_c = 0.6$ and $n_c = 0.02$. (a) Control signals (equations 11) μ_a , μ_b and μ_c (b) Control signals (equations 11) μ_d , μ_e and μ_f for keeping the system in synchronism.

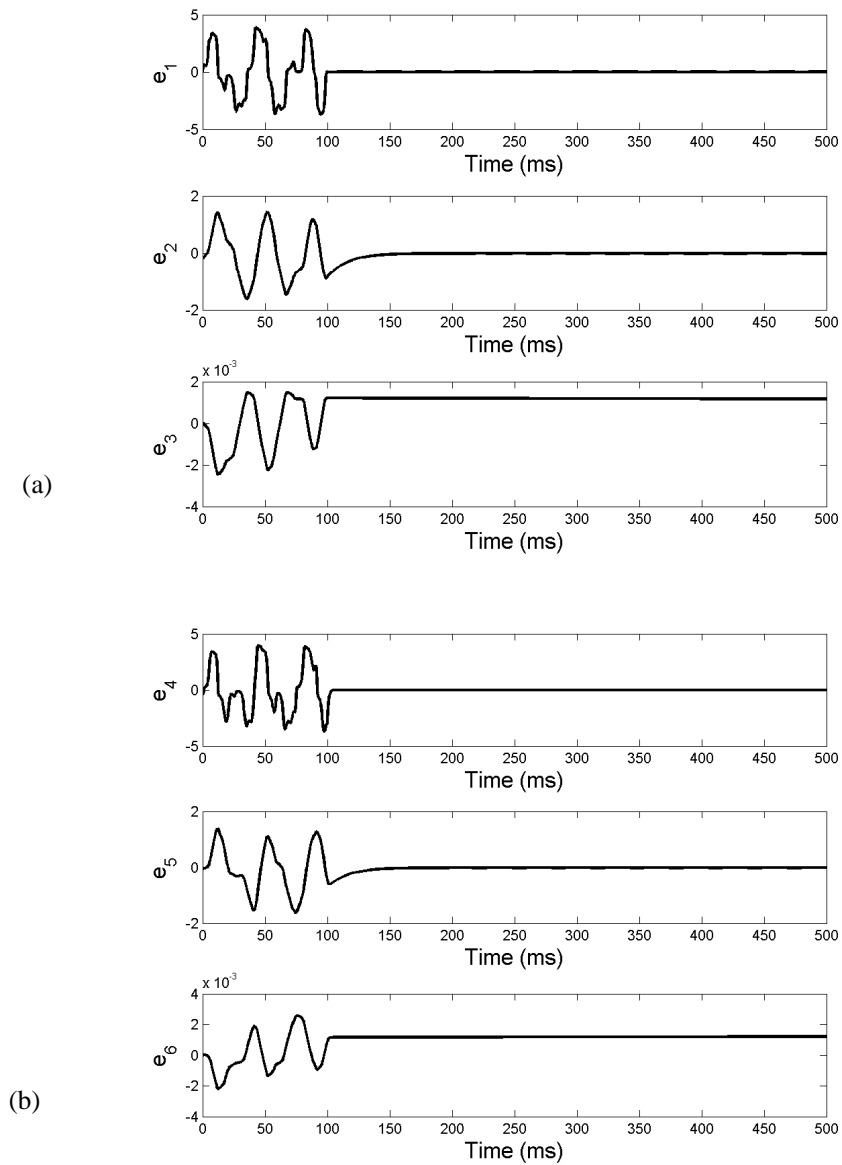

Fig. 12 Responses for pair of coupled neuron used with nonlinear active controller at different coupling strengths $g_c = 0.6$ and $n_c = 0.02$. (a) Error signals (equations 9) e_1 , e_2 and e_3 (b) Error signals (equations 9) e_4 , e_5 and e_6 .

Conclusion

In this paper, the characteristics of three dimensional modified FitzHugh-Nagumo neuron model is studied. Dynamical behavior of the modified FitzHugh-Nagumo system under external electrical stimulation is presented and it is verified that the introduction of periodic stimulation modifies the dynamics of biological system by presenting the dynamical behavior for the modified FitzHugh-Nagumo system under external electrical stimulation. The responses of the system for different stimulus frequencies are shown. The synchronization of two coupled neurons subjected to external electrical stimulation is studied. The behavior of coupled neurons with the variation in coupling strength is also studied. A nonlinear active controller description is provided at the end. It is shown that this controller can maintain the synchronous behavior among strongly-weakly coupled neurons. The methodology for determining control law is presented. We compared these results with the response of a nonlinear coupled neuron model in the absence of controlling mechanism. It is found that the application of active controller for maintaining synchronism in nonlinear system is very effective and can be used in real life applications.

References

- Gerstner W and Kistler WM. Spiking Neuron Models, Single Neurons, Populations, Plasticity, Cambridge University Press. 2002.
- Pinto RD, Varona P, Volkovskii AR et al. Synchronous behavior of two coupled electronic neurons. *Physical Review E* 2000;62:2644-2655.
- Ucar A, Lonngren KE, Bai WE. Synchronous of the Coupled FitzHugh-Nagumo System. *Chaos, Solitons and Fractals* 2004;20:1085-1090.
- Mishra D, Yadav A, Ray S, Kalra PK. Nonlinear Dynamical Analysis on Coupled Modified FitzHugh-Nagumo Neuron Model. *ISNN 2005, LNCS 3496, 2005;95-101*.
- Mishra D, Yadav A, Ray S, Kalra PK. Bifurcation analysis in modified Fitzhugh Nagumo neuronal model. *NCCDS* 2005.
- Jiang W, Bin D, Tsang KM. Chaotic synchronization of neurons coupled with gap junction under external electrical stimulation. *Chaos, Solitons and Fractals* 2004; 22:469-476.
- Thompson CJ, Bardos DC, Yang YS, Joyner KH. Nonlinear cable models for cells exposed to electric fields I. General Theory and Space-clamped Solutions. *Chaos, Solitons and Fractals* 1999;10(11):1825-1842.
- Hodgkin A and Huxley A. A quantitative description of membrane current and its application to conduction and excitation in nerve. *Journal of Physiology, London*, 1952;117:500-544.
- Nagumo J, Arimoto S and Yosizawa S. An active pulse transmission line simulating nerve axon. *Proc IRE*, 1962;50.
- FitzHugh R. Mathematical models for excitation and propagation in nerve. *Biological Engineering* 1969.
- Koch C. Biophysics of computation. Oxford University Press, 1999.
- Dyan P and Abbott LF. Theoretical neuroscience: computational and mathematical modeling of neural systems. The MIT Press, Massachusetts. 2001.
- Elsom RC, Selverston A, Huerta R, Rulkov NF, Rabinovich M, Abarbanel HDI. Synchronous behavior of two coupled biological neurons. *Physical Review Letters* 1999; 81: 5692-5695.
- Rinzel J. A formal classification of bursting mechanisms in excitable systems, in mathematical topics in population biology, morphogenesis and neuroscience. *Lecture notes in Biomathematics*. Springer-Verlag, New York, 1987; 71: 267-281.
- Chang HS, Staras K, Gilbey MP. Multiple Oscillators Provide Metastability in Rhythm Generation. *The Journal of Neuroscience* 2000; 20(13): 5135-5143.